

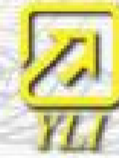

MALAYSIA

- SINGAPORE • CHINA
- IPOH • PETALING JAYA • JOHOR BAHRU • BUTTERWORTH
- KOTA KINABARU • MIRI



YLI INDUSTRY SDN. BHD.
ISO 9001:2008
 THE LIGHTS MAKER

CONTENTS



		INFORMATION		Page
		CONTENTS		1
		BRIEF INTRODUCTION		2
		PRODUCT SPECIFICATION		3
		IEC CLASSIFICATION OF PROTECTION	NEW	38
		ADEQUATE LIGHT LEVELS	NEW	38
		CALCULATION METHOD OF ILLUMINANCE	NEW	39
		PHOTOMETRIC DATA	NEW	40-44
STANDARD		A-Z INDEX BY PRODUCT NAME	MODEL	Page
MS	B	BARE CHANNEL FITTING	YBC	4
		BATTEN FITTING	Y	5
	C	CANLUX MIRROR LOUVER - type E	E	24
		CANLUX MIRROR LOUVER - type R	ML/R	24
		CANLUX MIRROR LOUVER - type RP	ML/RP	23
		CANLUX MIRROR LOUVER - type S	ML/S	23
		CEILING LIGHT	CLD	8
		CEILING LIGHT	SR	15
		COMPACT MIRROR LOUVER	CM	25
MS	D	DAIKON DIFFUSERFITTING	YDP	7
		DELUX MIRROR LOUVER - type EF	EF	25
		DOLPHIN PENDANT & RECESSED	DOLPHIN	NEW 18
		DOUBLE MIRROR LOUVER	DM	NEW 26
	H	HINGED DIFFUSER FITTING	HD	NEW 33
MS	I	INDIRECT FITTING - type A	YID/A	27
MS		INDIRECT FITTING - type FSG	YID/FSG	30
MS		INDIRECT FITTING - type SG	YID/SG	29
MS		INDIRECT FITTING - type V	YID/V	28
		INDIRECT LIGHT - type A	ID/A	31
		INDIRECT LIGHT - type M	ID/M	32
		INDIRECT LIGHT - type SG	ID/SG	32
		INDIRECT LIGHT - type V	ID/V	31
	L	LINKING FITTING	LF5	NEW 6
	M	METAL REFLECTOR	MER	34
		MIRROR REFLECTOR	MIR	34
MS		MIRROR LOUVER FITTING - type H	YML/H	21
MS		MIRROR LOUVER FITTING - type R	YML/R	20
MS		MIRROR LOUVER FITTING - type RP	YML/RP	22
MS		MIRROR LOUVER FITTING - type S	YML/S	19
		MIRROR PERFORATED FITTING	MP5	17
	R	ROUND DAIKON FITTING	RD	9
	S	SHARK CABINET LIGHT	CL	9
		SHARK CABINET LIGHT - WITH SWITCH	CL/SW	9
		SHOW CASE LIGHT	SLD	10
		SHOW CASE LIGHT type D	SLD/D	NEW 10
		SLIM BATTEN FITTING	YS	5
		SLIM MIRROR LOUVER FITTING	SML	17
		SUSPENSION SYSTEM	SCC	34
		SUSPENSION SYSTEM	SSR	34
	T	T5 BATTEN FITTING	Y5	6
		T5 WEATHER PROOF LIGHT	MT5	14
		T8 WEATHER PROOF LIGHT	MT	14
		TOSHIBA FLUORESCENT LAMP	TOSHIBA	NEW 35-36-37
		TRIANGLE FITTING	TMER	16
		TRIANGLE FITTING	TMIR	16
	W	WALL WASHER	VV	NEW 12
MS		WEATHER PROOF FITTING	YMT	13
MS		WIRE GUARD FITTING	YWG	11
		WIRE GUARD LIGHT	WG	12

CONTENTS



INFORMATION

	Page
CONTENTS	1
BRIEF INTRODUCTION	2
PRODUCT SPECIFICATION	3
IEC CLASSIFICATION OF PROTECTION	NEW 38
ADEQUATE LIGHT LEVELS	NEW 38
CALCULATION METHOD OF ILLUMINANCE	NEW 39
PHOTOMETRIC DATA	NEW 40-44

A-Z INDEX BY MODEL

PRODUCT NAME

Page

C	CL	SHARK CABINET LIGHT		9
	CL / SW	SHARK CABINET LIGHT - WITH SWITCH		9
	CLD	CEILING LIGHT		8
	CM	COMPACT MIRROR LOUVER		25
D	DM	DOUBLE MIRROR LOUVER	NEW	26
	DOLPHIN	DOLPHIN PENDANT & RECESSED	NEW	18
E	E	CANLUX MIRROR LOUVER - type E		24
	EF	DELUX MIRROR LOUVER - type EF		25
H	HD	HINGED DIFFUSER FITTING	NEW	33
I	ID/A	INDIRECT LIGHT FITTING - type A		31
	ID/M	INDIRECT LIGHT - type M		32
	ID/SG	INDIRECT LIGHT - type SG		32
	ID/V	INDIRECT LIGHT - type V		31
L	LF5	LINKING FITTING	NEW	6
M	MER	METAL REFLECTOR		34
	MIR	MIRROR REFLECTOR		34
	ML/RP	CANLUX MIRROR LOUVER - type RP		23
	ML/R	CANLUX MIRROR LOUVER - type R		24
	ML/S	CANLUX MIRROR LOUVER - type S		23
	MP5	MIRROR PERFORATED FITTING		17
	MT	T8 WEATHER PROOF LIGHT		14
	MT5	T5 WEATHER PROOF LIGHT	NEW	14
R	RD	ROUND DAIKON FITTING		9
S	SCC	SUSPENSION SYSTEM		34
	SLD	SHOW CASE LIGHT		10
	SLD/D	SHOW CASE LIGHT type D	NEW	10
	SML	SLIM MIRROR LOUVER FITTING		17
	SR	CEILING LIGHT		15
	SSR	SUSPENSION SYSTEM		34
T	TMER	TRIANGLE FITTING		16
	TMIR	TRIANGLE FITTING		16
	TOSHIBA	TOSHIBA FLUORESCENT LAMP	NEW	35-36-37
W	WG	WIRE GUARD LIGHT		12
	WW	WALL WASHER	NEW	12
Y	Y	BATTEN FITTING		5
	Y5	T5 BATTEN FITTING		6
	YS	SLIM BATTEN FITTING		5
	YBC	BARE CHANNEL FITTING		4
	YDP	DAIKON DIFFUSER FITTING		7
	YID/A	INDIRECT FITTING - type A		27
	YID/FSG	INDIRECT FITTING - type FSG		30
	YID/SG	INDIRECT FITTING - type SG		29
	YID/V	INDIRECT FITTING - type V		28
	YML/H	MIRROR LOUVER FITTING - type H		21
	YML/R	MIRROR LOUVER FITTING - type R		20
	YML/RP	MIRROR LOUVER FITTING - type RP		22
	YML/S	MIRROR LOUVER FITTING - type S		19
	YMT	WEATHER PROOF FITTING		13
	YWG	WIRE GUARD FITTING		11

STANDARD

MS			
MS			
MS			
MS			
MS			
MS			
MS			
MS			
MS			
MS			

YLI INDUSTRY SDN BHD established since 1993 has the experience in the moulding and tooling industry for more than 10 years. With its strong background, **YLI** diversified into lighting manufacturing & is now one of the fastest growing manufacturers of lighting fittings for interior & exterior applications in *Malaysia*

The core products of YLI are :-

INDOOR LIGHTING

Down Light ; Fluorescent Light Fitting ; Close Ceiling Light ; Pendant Light & Spot Track Lighting.

OUTDOOR LIGHTING

Flood Light ; Garden Light ; Wall light
Bollard Light & Up - down Light .

ACCESSORIES / ATTACHMENTS

Lamp Holder ; Anodized Reflector & Attachment.

With the combination of advanced moulding machines & in-house R & D , **YLI** manufactures high quality products for the global market at competitive pricing so as to meet their customers specific needs and requirements .



PRODUCT SPECIFICATION



HOUSING

FABRICATED FROM MILD STEEL, ELECTROSTATICALLY COATED WITH EPOXY AND/OR POLYESTER POWDER

LOUVER

ANODIZED ALUMINIUM, BRIGHT FINISHED AND ANODIZED ALUMINIUM RIBBED CROSS BLADE IN MATT FINISHED

DIFFUSER

ACRYLIC / POLYCARBONATE WITH VARIOUS FACET DESIGN, PERFORATED MILD STEEL

BALLAST

MAGNETIC OR ELECTRONIC TYPE

HOLDER

MOULDED HOUSING FROM POLYCARBONATE WITH BRONZE CONDUCTOR

LIGHT SOURCE

FLUORESCENT LAMP T8 AND T5 MAINLY

DEGREE OF PROTECTION

IP 20, IP 65

TYPE OF PROTECTION

CLASS 1

ELECTRICAL

240Vac, 50Hz, AS STANDARD
OTHERS STANDARD ON REQUEST

FEATURES

IDEAL FOR
- SURFACE MOUNTING ON CEILING AND WALL
- PENDANT MOUNTING BY SUSPENSION SYSTEM
- RECESSED MOUNTING IN TEE-BAR CEILING OR PLASTER CEILING

APPLICATION

IP 20
- SUITABLE FOR MOST OF THE INDOOR AREA OF COMMERCIAL, INDUSTRIAL AND DOMESTIC

IP 65
- SUITABLE FOR OUTDOOR AREA WHERE LIGHTS IS NEEDED

RIGHTS

YLI INDUSTRY SDN.BHD. RESERVES THE RIGHT TO CHANGE THE PRODUCT SPECIFICATION AT ANY TIME WITHOUT NOTICE

BARE CHANNEL FITTING

IP 20

CLASS 1

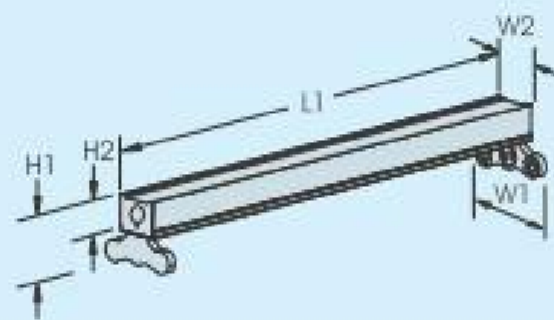

MODEL	FOR LAMP T8	DIMENSION - mm						POWER AT 240vac	
		L1	L2	W1	W2	H1	H2	AMP.	P.F/ lag.
YBC 118	1 x 18w	610	-	52	52	77	43	0.112	0.934
YBC 218	2 x 18w	610	-	102	52	82	43	0.227	0.927
YBC 136	1 x 36w	1220	-	52	52	77	43	0.181	0.932
YBC 236	2 x 36w	1220	-	102	52	82	43	0.383	0.901

PHOTOMETRIC DATA

POLAR CURVE

UTILISATION FACTORS

LUMINAIRE : YBC 136
 FLU. TUBE : 1 x 36w/T8, 3250 lm

L.O.R. 63.3% I_{max}(cd) 470.6

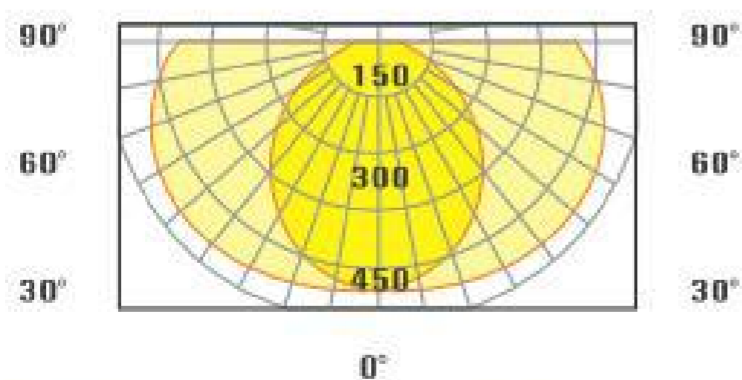

AVERAGE BEAM ANGLE (30%) 157.8 DEG

MORE DATA ON PAGE 40 TO 44

REFLECTANCE

CEILING	0.8	0.8	0.8	0.7	0.7	0.7	0.5	0.5	0.5	0
WALL	0.7	0.5	0.3	0.7	0.5	0.3	0.7	0.5	0.3	0
FLOOR	0.2	0.2	0.2	0.2	0.2	0.2	0.2	0.2	0.2	0
Rm. Index	UTILISATION FACTORS IN PERCENT (%)									K(RI) x RCR = 5
K = 0.60	34	25	19	33	24	19	31	24	19	13
0.80	40	31	24	39	30	24	36	29	23	18
1.00	45	36	29	43	35	29	41	34	28	22
1.25	49	40	34	47	40	34	45	38	33	26
1.50	52	44	38	50	43	37	47	41	36	29
2.00	56	49	43	55	48	43	51	46	41	34
2.50	59	53	47	57	51	46	54	49	45	38
3.00	61	56	50	59	54	50	56	52	48	41
4.00	64	59	55	62	58	54	59	55	52	44
5.00	66	62	58	64	60	57	61	57	54	47
Room Index	UF (TOTAL)									Direct
According to DIN EN 13032-2 2004 Ceiling Mounted SHR _{NOM} = 1.25										

BATTEN FITTING

IP 20

CLASS 1

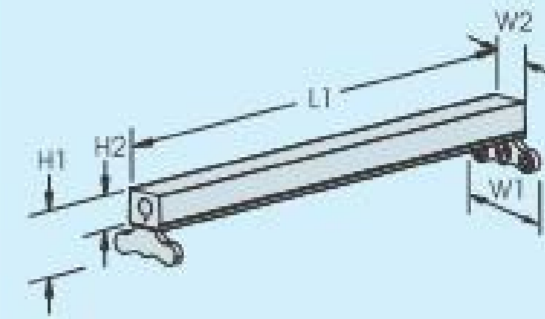

MODEL	FOR LAMP T8	DIMENSION - mm					
		L1	L2	W1	W2	H1	H2
Y 110	1 x 10w	310	-	52	52	70	36
Y 115	1 x 15w	460	-	52	52	70	36
Y 130	1 x 30w	915	-	52	52	70	36
Y 120	1 x 18w	610	-	52	52	70	36
Y 220	2 x 18w	610	-	102	52	78	36
Y 140	1 x 36w	1220	-	52	52	70	36
Y 240	2 x 36w	1220	-	102	52	78	36
Y 165	1 x 58w	1525	-	52	52	70	36
Y 265	2 x 58w	1525	-	102	52	78	36

SLIM BATTEN FITTING

IP 20

CLASS 1

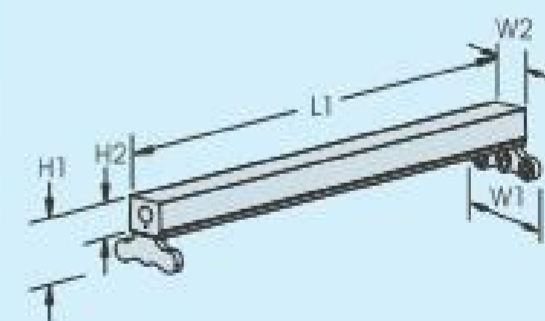

MODEL	FOR LAMP T8	DIMENSION - mm					
		L1	L2	W1	W2	H1	H2
YS 110	1 x 10w	310	-	42	42	65	31
YS 115	1 x 15w	460	-	42	42	65	31
YS 130	1 x 30w	915	-	42	42	65	31
YS 120	1 x 18w	610	-	42	42	65	31
YS 220	2 x 18w	610	-	88	42	65	31
YS 140	1 x 36w	1220	-	42	42	65	31
YS 240	2 x 36w	1220	-	88	42	65	31

T5 BATTEN FITTING

IP 20

CLASS 1

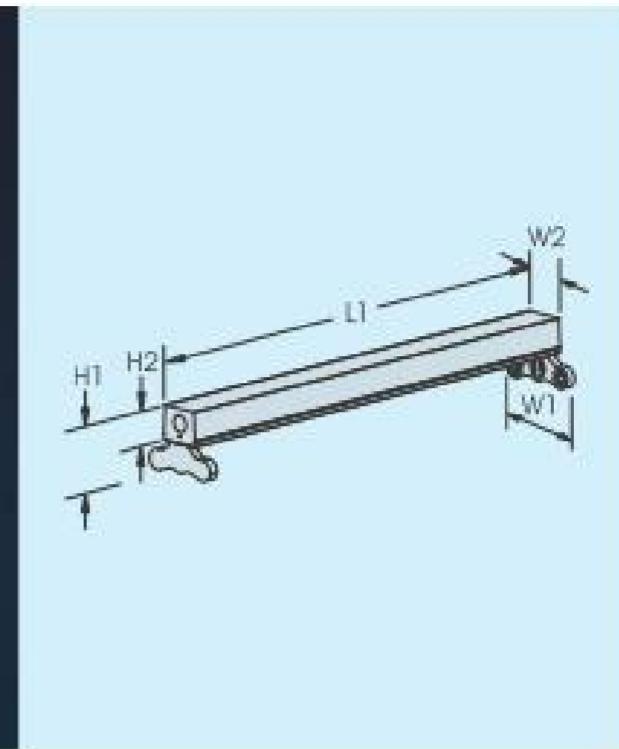

MODEL	FOR LAMP T5	DIMENSION - mm					
		L1	L2	W1	W2	H1	H2
Y5 114	1 x 14w	567	-	42	42	53	31
Y5 121	1 x 21w	867	-	42	42	53	31
Y5 128	1 x 28w	1167	-	42	42	53	31
Y5 135	1 x 35w	1467	-	42	42	53	31
Y5 214	2 x 14w	567	-	75	42	62	31
Y5 221	2 x 21w	867	-	75	42	62	31
Y5 228	2 x 28w	1167	-	75	42	62	31
Y5 235	2 x 35w	1467	-	75	42	62	31

LINKING FITTING

IP 20

CLASS 1

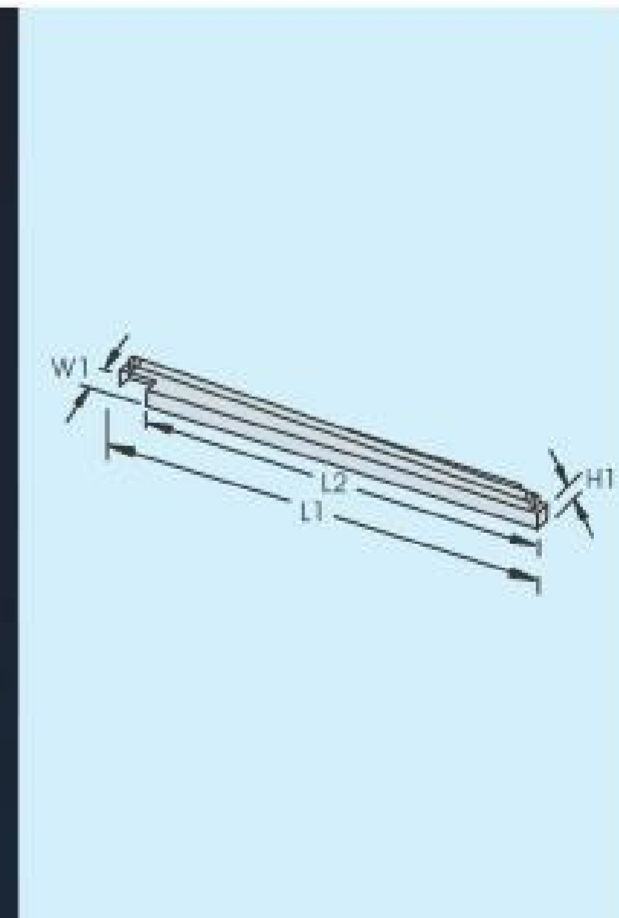

MODEL	FOR LAMP T5	DIMENSION - mm					
		L1	L2	W1	W2	H1	H2
LF5 114	1 x 14w	590	-	75	-	35	-
LF5 121	1 x 21w	890	-	75	-	35	-
LF5 128	1 x 28w	1190	-	75	-	70	-
LF5 135	1 x 35w	1490	-	75	-	70	-

LINKING FITTINGS FOR T8 LAMP ARE AVAILABLE ON REQUEST

DAIKON DIFFUSER FITTING

IP 20

CLASS 1



SELECTION : FACET DESIGN OF DIFFUSER

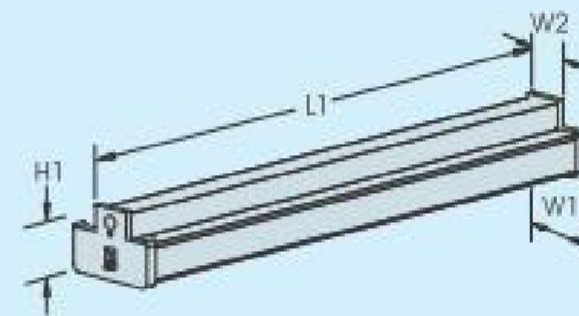
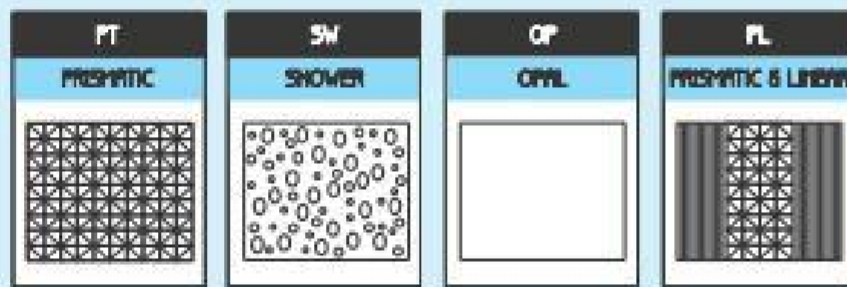

MODEL	FOR LAMP T8	DIMENSION - mm						POWER AT 240vac	
		L1	L2	W1	W2	H1	H2	AMP.	PF/ lag.
YDP 118	1 x 18w	620	-	60	60	95	-	0.109	0.913
YDP 218	2 x 18w	620	-	130	60	95	-	0.219	0.900
YDP 136	1 x 36w	1230	-	60	60	95	-	0.180	0.921
YDP 236	2 x 36w	1230	-	130	60	95	-	0.346	0.950

EXAMPLE OF ORDERING : YDP 118/PT OR YDP 118/PL

PHOTOMETRIC DATA

POLAR CURVE

UTILISATION FACTORS

LUMINAIRE: YDP 136
FLU. TUBE : 1 x 36w/T8, 3250 lm

L.O.R. 56.3% $I_{max}(cd)$ 429.5

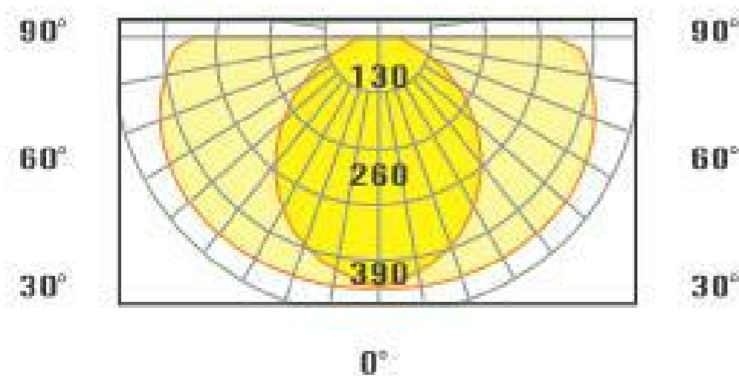

$C0^\circ/180^\circ$ $C90^\circ/270^\circ$

AVERAGE BEAM ANGLE (30%) 156.8 DEG

MORE DATA ON PAGE 40 TO 44

REFLECTANCE

CEILING	0.8	0.8	0.8	0.7	0.7	0.7	0.5	0.5	0.5	0
WALL	0.7	0.5	0.3	0.7	0.5	0.3	0.7	0.5	0.3	0
FLOOR	0.2	0.2	0.2	0.2	0.2	0.2	0.2	0.2	0.2	0

Rm. Index	UTILISATION FACTORS IN PERCENT (%)										K(RI) x RCR = 5
K = 0.60	30	22	17	30	22	17	28	21	17	12	
	0.80	36	27	22	35	27	22	32	26	21	16
1.00	40	32	26	39	31	26	36	30	25	20	
1.25	44	36	31	42	35	30	40	34	29	24	
1.50	46	39	34	45	38	33	42	37	32	26	
2.00	50	44	39	49	43	38	46	41	37	31	
2.50	53	47	42	51	46	41	48	44	40	34	
3.00	55	50	45	53	48	44	50	46	43	36	
4.00	57	53	49	55	52	48	52	49	46	40	
5.00	59	55	52	57	54	51	54	51	49	42	

Room Index UF (TOTAL) Direct

According to DIN EN 13032-2 2004 Ceiling Mounted SHR NOM = 1.25

CEILING LIGHT type CLD for surface mounting



IP 20

CLASS 1

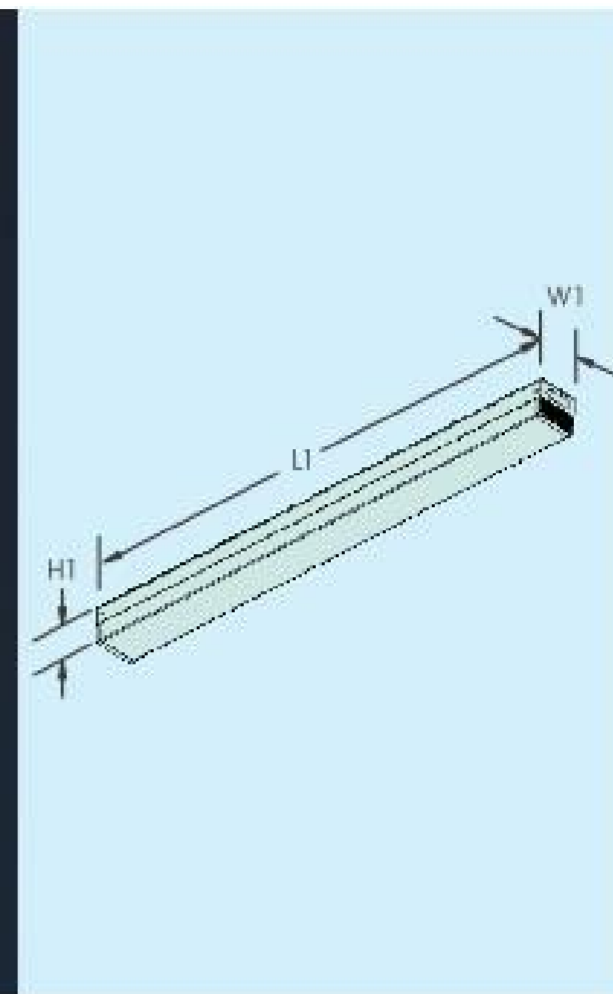

MODEL	FOR LAMP T8	DIMENSION - mm					
		L1	L2	W1	W2	H1	H2
CLD 120	1 x 18w	625	-	100	-	86	-
CLD 130	1 x 30w	925	-	100	-	86	-
CLD 140	1 x 36w	1235	-	100	-	86	-

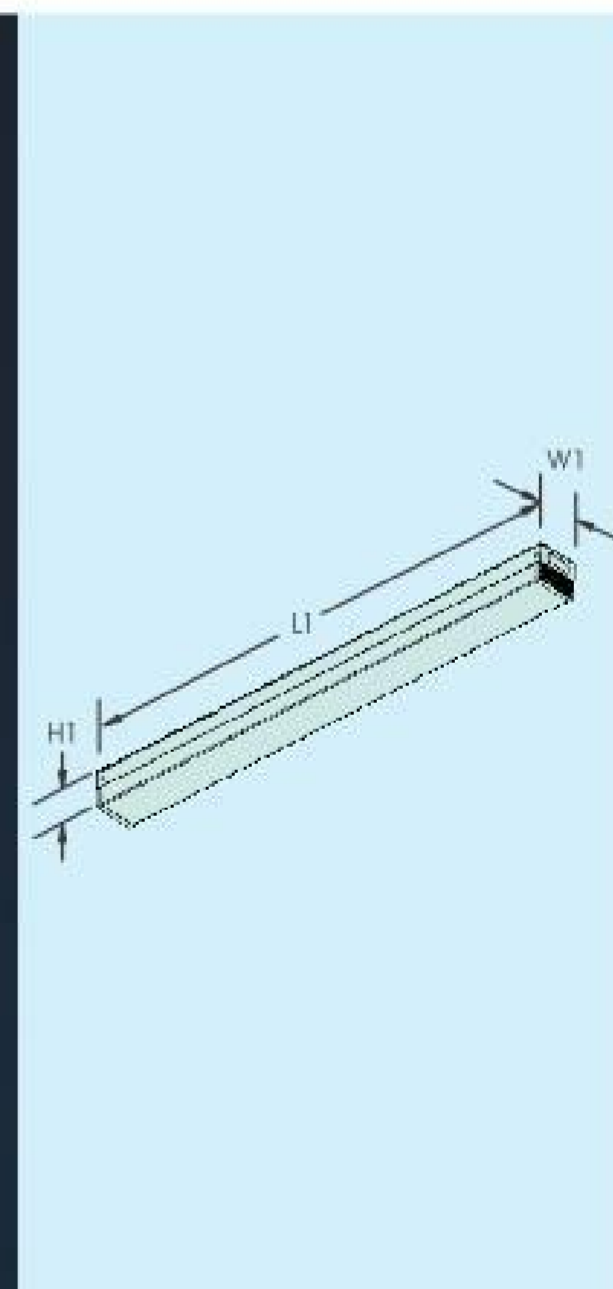

MODEL	FOR LAMP T8	DIMENSION - mm					
		L1	L2	W1	W2	H1	H2
CLD 220	2 x 18w	625	-	150	-	70	-
CLD 230	2 x 30w	925	-	150	-	70	-
CLD 240	2 x 36w	1235	-	150	-	70	-

ROUND DAIKON FITTING

IP 20

CLASS 1

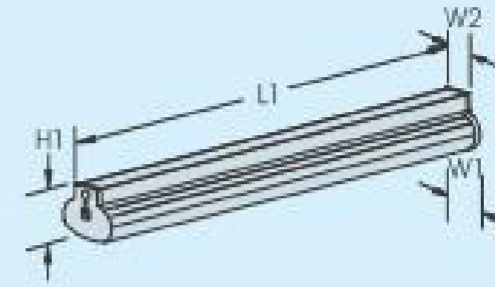

SELECTION :
FACET DESIGN OF DIFFUSER

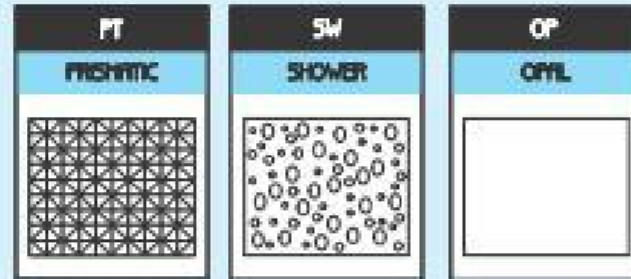

MODEL	FOR LAMP T8	DIMENSION - mm					
		L1	L2	W1	W2	H1	H2
RD 120	1 x 18w	620	-	62	52	90	-
RD 220	2 x 18w	620	-	132	52	90	-
RD 140	1 x 36w	1230	-	62	52	90	-
RD 240	2 x 36w	1230	-	132	52	90	-

EXAMPLE OF ORDERING : RD 120/PT OR RD120/OP

SHARK CABINET LIGHT

IP 20

CLASS 1

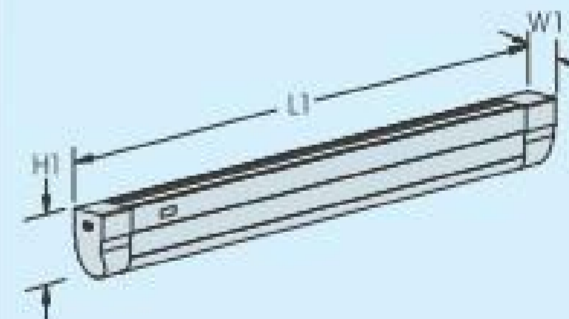

MODEL	FOR LAMP T8	DIMENSION - mm					
		L1	L2	W1	W2	H1	H2
UN-SWITCH TYPE							
CL 120	1 x 18w	645	-	40	-	72	-
CL 130	1 x 30w	950	-	40	-	72	-
CL 140	1 x 36w	1255	-	40	-	72	-
SWITCHED TYPE							
CL 120/SW	1 x 18w	645	-	40	-	72	-
CL 130/SW	1 x 30w	950	-	40	-	72	-
CL 140/SW	1 x 36w	1255	-	40	-	72	-

SHOW CASE LIGHT

IP 20

CLASS 1

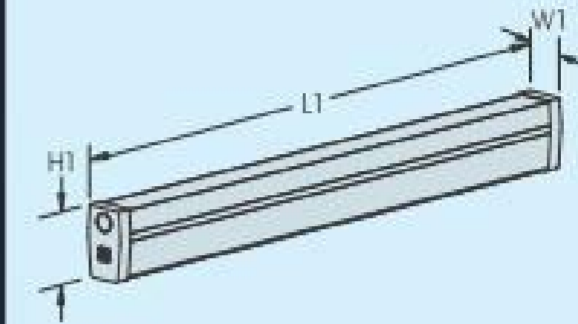

MODEL	FOR LAMP T8	DIMENSION - mm					
		L1	L2	W1	W2	H1	H2
SLD 120	1 x 18w	625	-	47	-	73	-
SLD 130	1 x 30w	920	-	47	-	73	-
SLD 140	1 x 36w	1225	-	47	-	73	-

SHOW CASE LIGHT type D

IP 20

CLASS 1

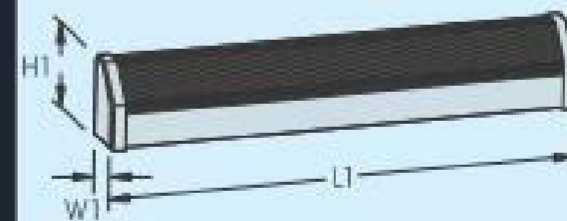

MODEL	FOR LAMP T8	DIMENSION - mm					
		L1	L2	W1	W2	H1	H2
SLD 120 D	1 x 18w	632	-	109	-	65	-
SLD 130 D	1 x 30w	932	-	109	-	65	-
SLD 140 D	1 x 36w	1237	-	109	-	65	-

WIRE GUARD FITTING

IP 20

CLASS 1

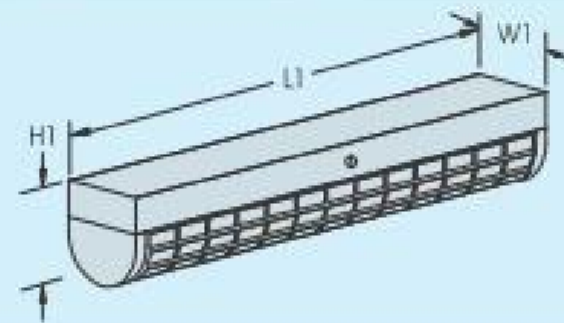

MODEL	FOR LAMP T8	DIMENSION - mm						POWER AT 240vac	
		L1	L2	W1	W2	H1	H2	AMP.	P.F/ lag.
YWG 118	1 x 18w	613	-	68	-	95	-	0.114	0.933
YWG 218	2 x 18w	613	-	100	-	106	-	0.221	0.908
YWG 136	1 x 36w	1222	-	68	-	95	-	0.183	0.929
YWG 236	2 x 36w	1222	-	100	-	106	-	0.366	0.927

FITTING WITH BUILT-IN CAM LOCK AND KEY

PHOTOMETRIC DATA

POLAR CURVE

UTILISATION FACTORS

LUMINAIRE: YWG 136
 FLU. TUBE : 1 x 36w/T8, 3250 lm

L.O.R. 59.2% I_{max}(cd) 455.4

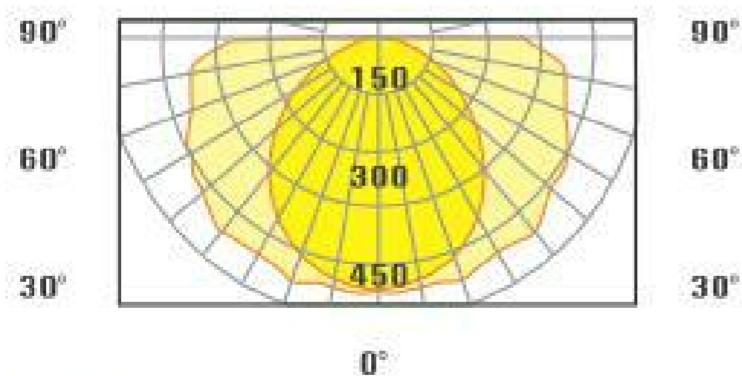

CO°/180° C90°/270°

AVERAGE BEAM ANGLE (30%) 158.5 DEG

MORE DATA ON PAGE 40 TO 44

REFLECTANCE

CEILING	0.8	0.8	0.8	0.7	0.7	0.7	0.5	0.5	0.5	0
WALL	0.7	0.5	0.3	0.7	0.5	0.3	0.7	0.5	0.3	0
FLOOR	0.2	0.2	0.2	0.2	0.2	0.2	0.2	0.2	0.2	0

Rm. Index	UTILISATION FACTORS IN PERCENT (%)										K/RI) x RCR = 5
K= 0.60	32	24	19	32	24	18	30	23	18	13	
0.80	38	29	24	37	29	23	35	28	23	18	
1.00	43	34	29	41	34	28	39	32	27	22	
1.25	46	39	33	45	38	32	42	36	32	26	
1.50	49	42	36	48	41	36	45	39	35	29	
2.00	53	47	42	52	46	41	49	44	40	33	
2.50	56	50	45	54	49	44	51	47	43	36	
3.00	58	53	48	56	51	47	53	49	46	39	
4.00	60	56	52	59	55	51	55	52	49	42	
5.00	62	58	55	60	57	54	57	54	52	45	

Room Index UF (TOTAL) Direct

According to DIN EN 13032-2 2004 Ceiling Mounted SHR NOM = 1.25

WIRE GUARD LIGHT

IP 20

CLASS 1

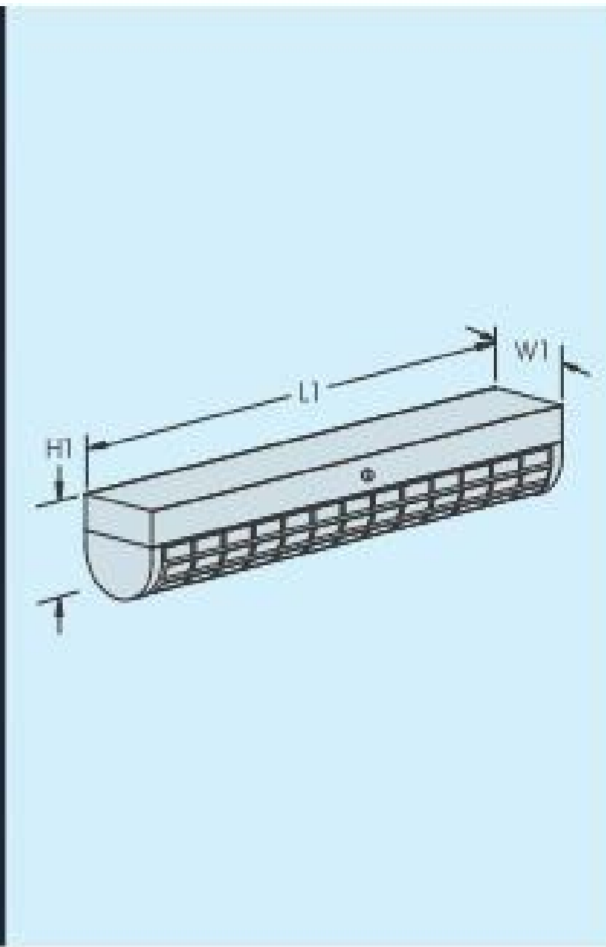

MODEL	FOR LAMP T8	DIMENSION - mm					
		L1	L2	W1	W2	H1	H2
WG 120	1 x 18w	613	-	68	-	95	-
WG 220	2 x 18w	613	-	100	-	106	-
WG 140	1 x 36w	1222	-	68	-	95	-
WG 240	2 x 36w	1222	-	100	-	106	-

FITTING FOR T5 LAMP IS AVAILABLE ON REQUEST

WALL WASHER for surface mounting

IP 20

CLASS 1

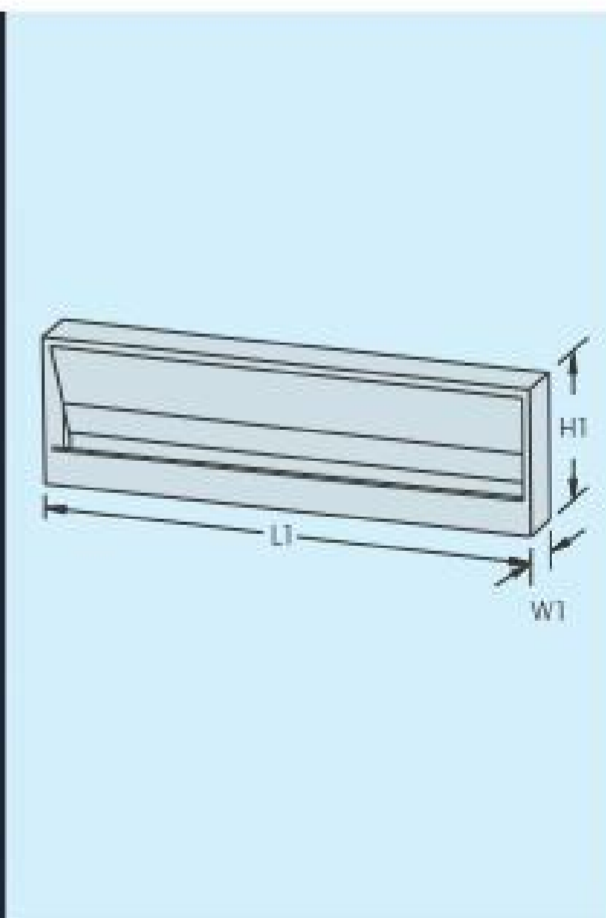

MODEL	FOR LAMP MULTIPLE	DIMENSION - mm					
		L1	L2	W1	W2	H1	H2
WW 124	1 x 24w/PLL	400	-	200	-	70	-
WW 120	1 x 18w/T8	615	-	200	-	70	-
WW 130	1 x 30w/T8	1020	-	200	-	70	-
WW 140	1 x 36w/T8	1220	-	200	-	70	-

T8 WEATHER PROOF FITTING

IP 65

CLASS 1



MODEL	FOR LAMP T8	DIMENSION - mm						POWER AT 240vac	
		L1	L2	W1	W2	H1	H2	AMP.	PF/ lag.
YMT 118	1 x 18w	660	-	86	-	90	-	0.114	0.934
YMT 218	2 x 18w	660	-	136	-	90	-	0.221	0.920
YMT 136	1 x 36w	1270	-	86	-	90	-	0.180	0.938
YMT 236	2 x 36w	1270	-	136	-	90	-	0.352	0.961

PHOTOMETRIC DATA

POLAR CURVE

UTILISATION FACTORS

LUMINAIRE: YMT 136
 FLU. TUBE : 1 x 36w/T8, 3250 lm

L.O.R. 59.8% $I_{max}(cd)$ 463.4

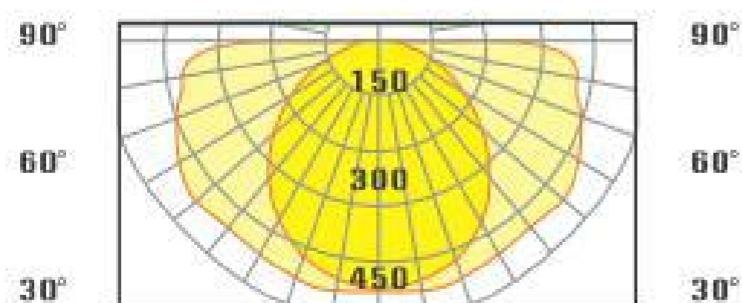

$C0^\circ/180^\circ$ $C90^\circ/270^\circ$

AVERAGE BEAM ANGLE (30%) 155.7 DEG

MORE DATA ON PAGE 40 TO 44

REFLECTANCE

CEILING	0.8	0.8	0.8	0.7	0.7	0.7	0.5	0.5	0.5	0
WALL	0.7	0.5	0.3	0.7	0.5	0.3	0.7	0.5	0.3	0
FLOOR	0.2	0.2	0.2	0.2	0.2	0.2	0.2	0.2	0.2	0

Rm. Index	UTILISATION FACTORS IN PERCENT (%)										K/RI) x RCR = 5
K= 0.60	33	24	19	32	24	19	30	23	18	14	
0.80	38	30	24	37	29	24	35	28	23	18	
1.00	43	34	29	42	34	28	39	32	28	22	
1.25	47	39	33	45	38	33	43	37	32	26	
1.50	50	42	37	48	41	36	45	40	35	29	
2.00	54	47	42	52	46	41	49	44	40	33	
2.50	56	50	45	55	49	45	51	47	43	36	
3.00	58	53	48	57	52	48	53	49	46	39	
4.00	61	56	52	59	55	51	56	53	50	43	
5.00	63	59	55	61	57	54	58	55	52	45	

Room Index UF (TOTAL) Direct

According to DIN EN 13032-2 2004 Ceiling Mounted SHR NOM = 1.25

T5 WEATHER PROOF LIGHT

IP 65

CLASS 1

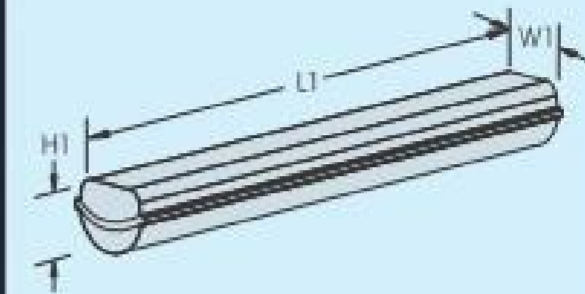

MODEL	FOR LAMP T5	DIMENSION - mm					
		L1	L2	W1	W2	H1	H2
MT5 114	1 x 14w	610	-	60	-	74	-
MT5 214	2 x 14w	610	-	100	-	74	-
MT5 128	1 x 28w	1210	-	60	-	74	-
MT5 228	2 x 28w	1210	-	100	-	74	-
MT5 135	1 x 35w	1510	-	60	-	74	-
MT5 235	2 x 35w	1510	-	100	-	74	-

T8 WEATHER PROOF LIGHT

IP 65

CLASS 1

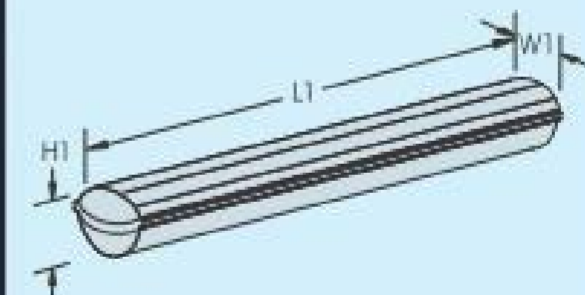

MODEL	FOR LAMP T8	DIMENSION - mm					
		L1	L2	W1	W2	H1	H2
MT 120	1 x 18w	600	-	100	-	110	-
MT 220	2 x 18w	600	-	150	-	110	-
MT 140	1 x 36w	1270	-	100	-	110	-
MT 240	2 x 36w	1270	-	150	-	110	-

CEILING LIGHT type SR

for surface mounting



IP 20

CLASS 1

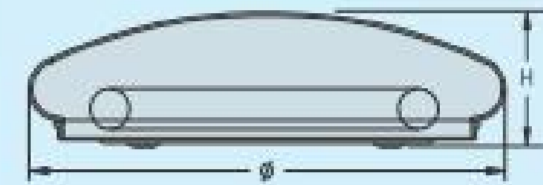

MODEL	FOR LAMP T8 CIRCULAR	IMPERIAL APPROX.	DIMENSION - mm	
			DIAMETER	HEIGHT
SR 500	1 x 22w	ø 12"	300	84
SR 501	1 x 32w	ø 15"	390	84
SR 502	1 x 40w	ø 20"	500	84

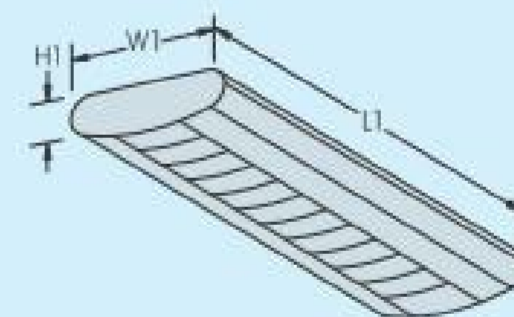

MODEL	FOR LAMP PLS/T8	IMPERIAL APPROX.	DIMENSION - mm					
			L1	L2	W1	W2	H1	H2
SR 700-209	2 x 9w PLS	8" x 9"	211	-	235	-	65	-
SR 700-211	2 x 11w PLS	8" x 11"	274	-	235	-	65	-
SR 702-220	2 x 18w T8	8" x 24"	615	-	235	-	65	-
SR 702-240	2 x 36w T8	8" x 48"	1235	-	235	-	65	-

TRIANGLE FITTING type T8

for surface mounting

IP 20

CLASS 1

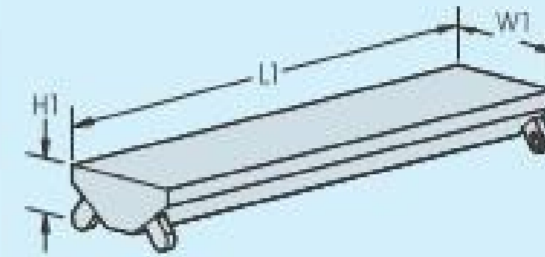

MODEL	FOR LAMP T8	IMPERIAL APPROX.	DIMENSION - mm					
			L1	L2	W1	W2	H1	H2
MIRROR REFLECTOR TYPE								
TMIR 220	2 x 18w	0.5' x 2'	612	-	152	-	63	-
TMIR 240	2 x 36w	0.5' x 4'	1222	-	152	-	63	-
METAL REFLECTOR TYPE								
TMER 220	2 x 18w	0.5' x 2'	612	-	152	-	63	-
TMER 240	2 x 36w	0.5' x 4'	1222	-	152	-	63	-

TRIANGLE FITTING type T5

for surface mounting

IP 20

CLASS 1

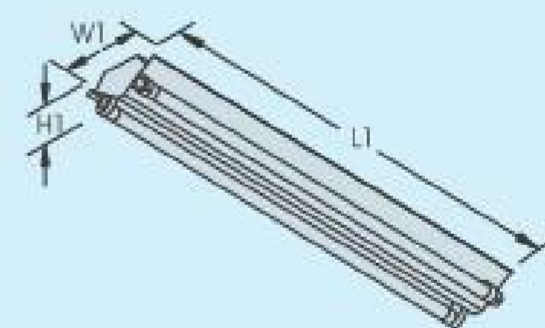

MODEL	FOR LAMP T5	IMPERIAL APPROX.	DIMENSION - mm					
			L1	L2	W1	W2	H1	H2
MIRROR REFLECTOR TYPE								
TMIR 214	2 x 14w	0.4' x 2'	570	-	120	-	52	-
TMIR 228	2 x 28w	0.4' x 4'	1170	-	120	-	52	-
METAL REFLECTOR TYPE								
TMER 214	2 x 14w	0.4' x 2'	570	-	120	-	52	-
TMER 228	2 x 28w	0.4' x 4'	1170	-	120	-	52	-

MIRROR PERFORATED FITTING

for recessed mounting



IP 20

CLASS 1

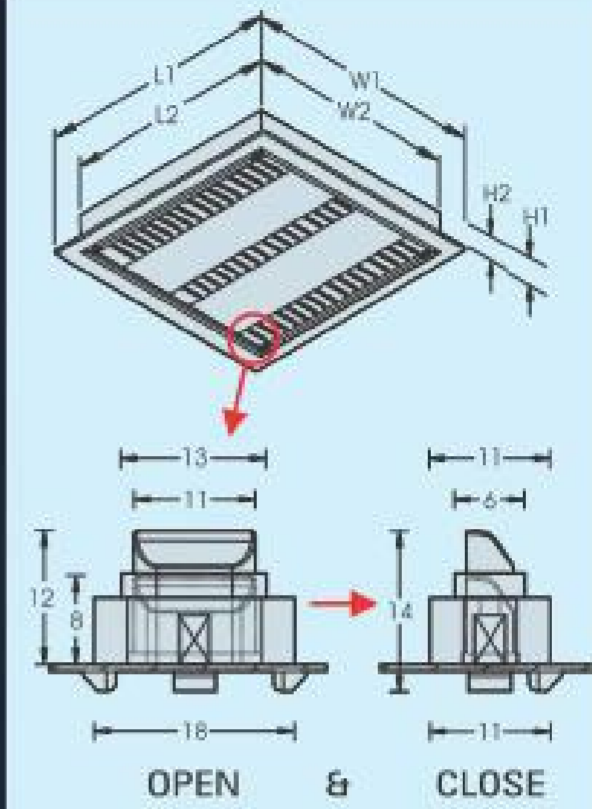

MODEL	FOR LAMP T5	IMPERIAL APPROX.	DIMENSION - mm					
			L1	L2	W1	W2	H1	H2
MP5 21412/R	2 x 14w/T5	1' x 2'	595	575	295	275	65	60
MP5 31422/R	3 x 14w/T5	2' x 2'	595	575	595	575	65	60
MP5 41422/R	4 x 14w/T5	2' x 2'	595	575	595	575	65	60
MP5 22814/R	2 x 28w/T5	1' x 4'	1195	1175	295	275	65	60
MP5 32824/R	3 x 28w/T5	2' x 4'	1195	1175	595	575	65	60
MP5 42824/R	4 x 28w/T5	2' x 4'	1195	1175	595	575	65	60

SLIM MIRROR LOUVER FITTING

for surface mounting



IP 20

CLASS 1

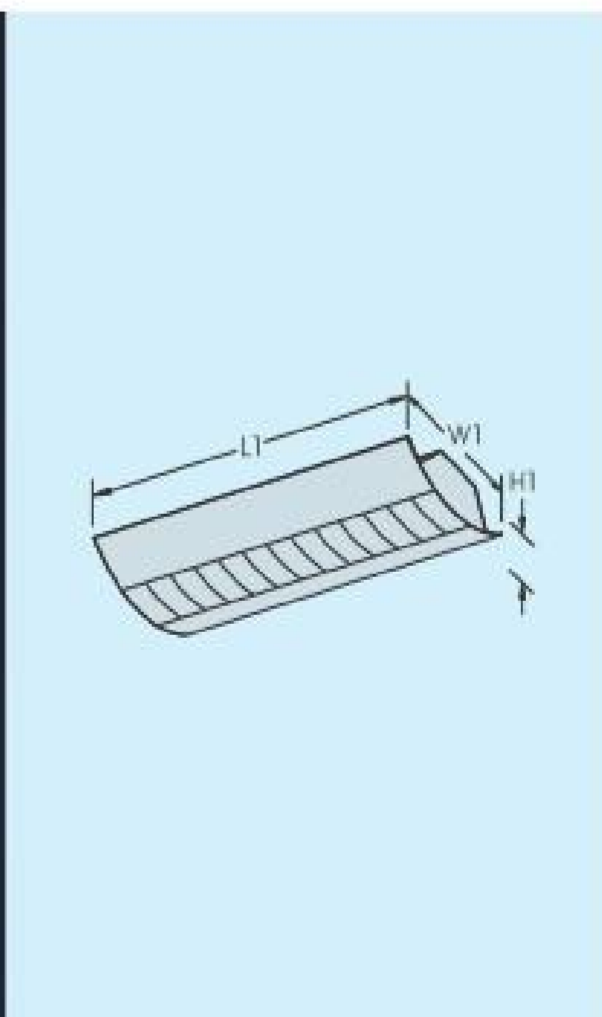

MODEL	FOR LAMP T8	IMPERIAL APPROX.	DIMENSION - mm					
			L1	L2	W1	W2	H1	H2
SML 001-320	3 x 18w	1' x 2.3'	725	-	285	-	99	-
SML 001-340	3 x 36w	1' x 4.3'	1335	-	285	-	99	-

IP 20

CLASS 1

DOLPHIN

for pendant mounting

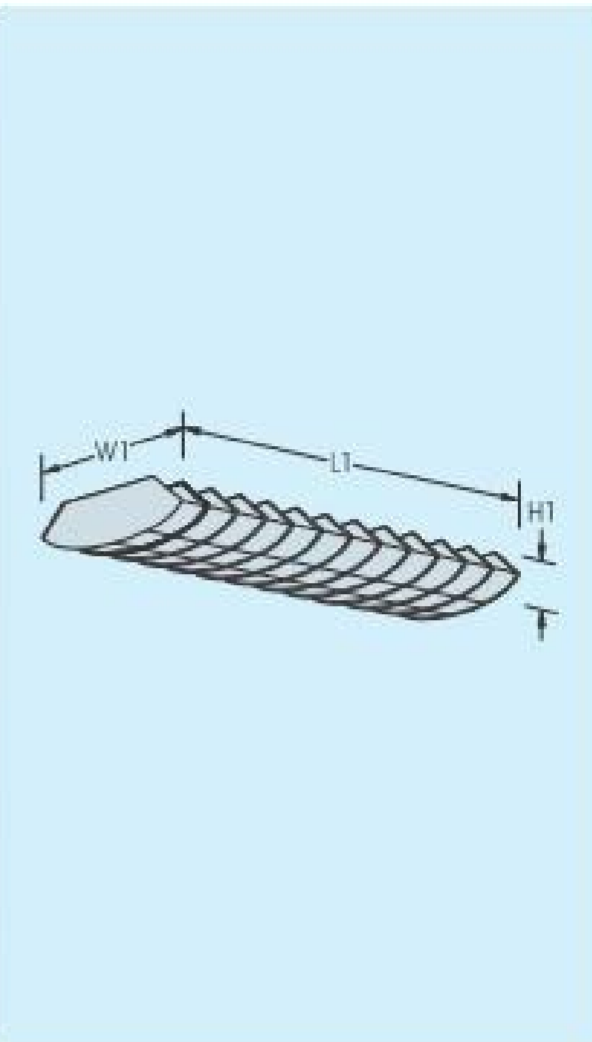
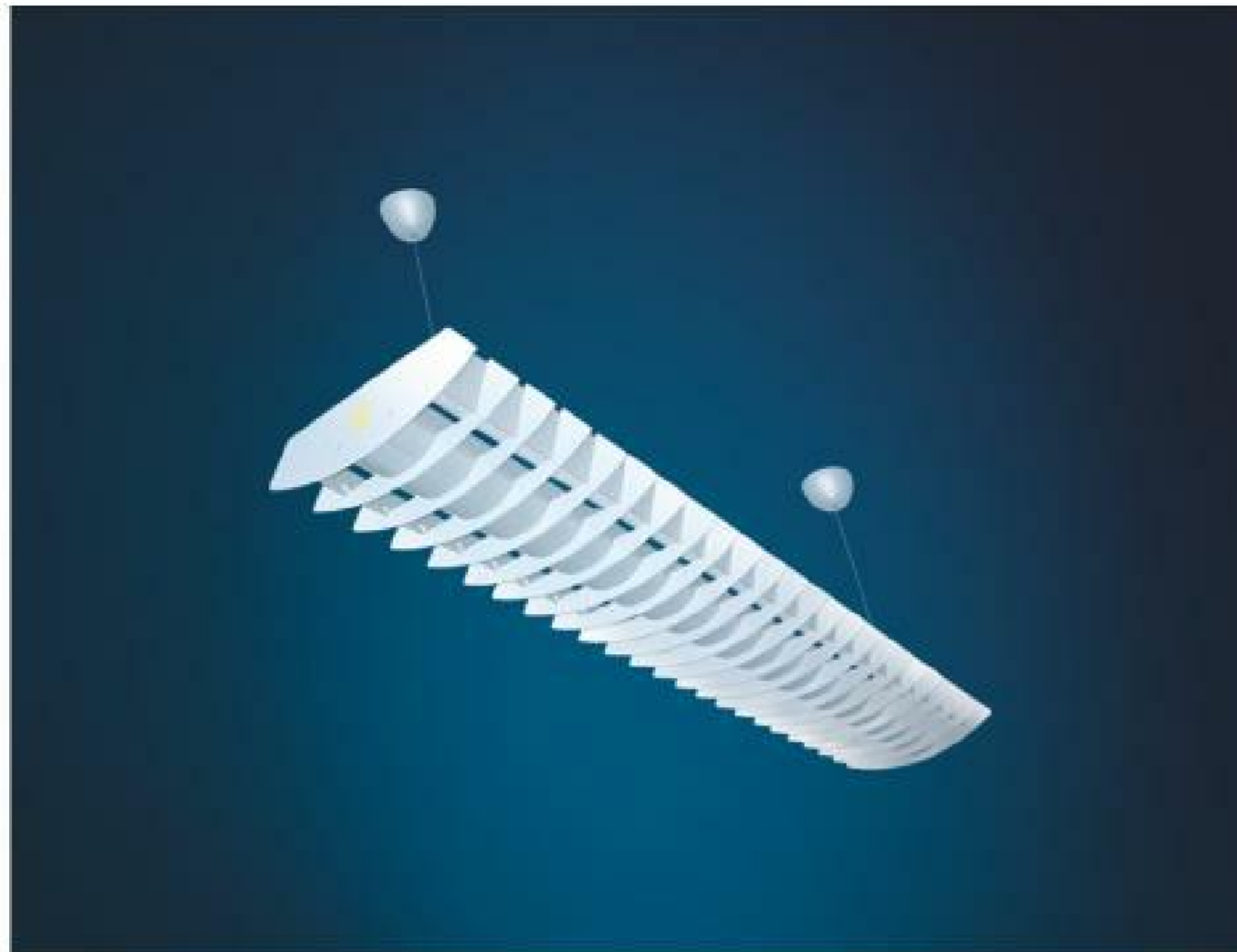

MODEL	FOR LAMP T8	IMPERIAL APPROX.	DIMENSION - mm					
			L1	L2	W1	W2	H1	H2
DOLPHIN 220	2 x 18w	1' x 2'	620	-	274	-	80	-
DOLPHIN 240	2 x 36w	1' x 4'	1228	-	274	-	80	-

FITTING C/WITH 2 x CEILING CAP , 2 x PENDANT STEEL CABLE L 300 mm & 1 x ELECTRICAL WIRE L 300 mm

IP 20

CLASS 1

DOLPHIN

for recessed plaster ceiling

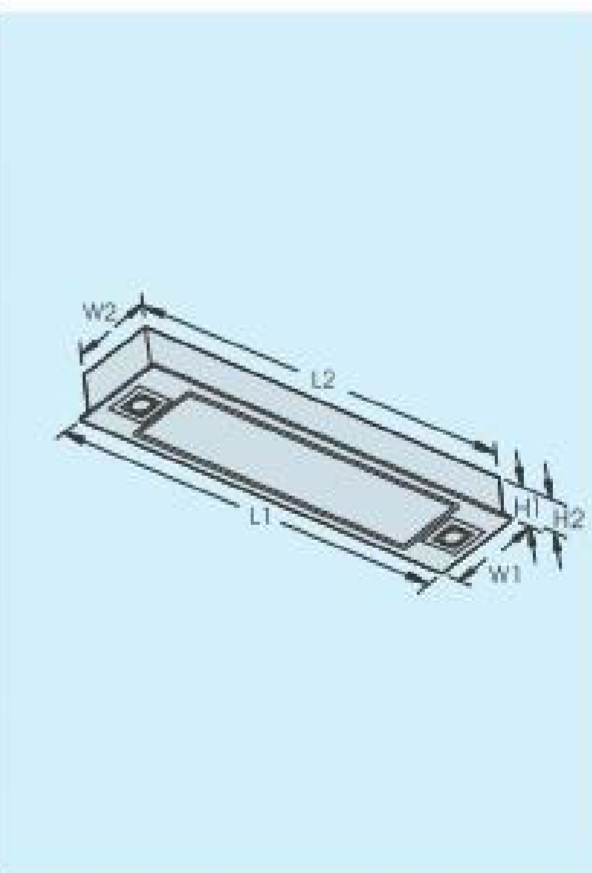

MODEL	FOR LAMP MULTIPLE T5 , T8 , HALOGEN MR 16	DIMENSION - mm					
		L1	L2	W1	W2	H1	H2
DOLPHIN 5-314	3 x 14w/T5, 2 x 50w/MR16	860	830	260	230	130	124
DOLPHIN 5-321	3 x 21w/T5, 2 x 50w/MR16	1160	1130	260	230	130	124
DOLPHIN 5-328	3 x 28w/T5, 2 x 50w/MR16	1460	1430	260	230	130	124
DOLPHIN 8-220	2 x 18w/T8, 2 x 50w/MR16	1160	1130	260	230	130	124
DOLPHIN 8-240	2 x 36w/T8, 2 x 50w/MR16	1460	1430	260	230	130	124

MIRROR LOUVER FITTING type S

for surface mounting

IP 20

CLASS 1

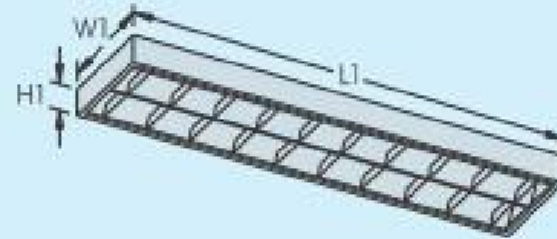

MODEL	FOR LAMP T8	IMPERIAL APPROX.	DIMENSION - mm						POWER AT 240vac	
			L1	L2	W1	W2	H1	H2	AMP.	PF/ lag.
YML 2222/S	2 x 18w	2' x 2'	615	-	605	-	80	-	0.234	0.903
YML 3222/S	3 x 18w	2' x 2'	615	-	605	-	80	-	0.338	0.927
YML 4222/S	4 x 18w	2' x 2'	615	-	605	-	80	-	0.452	0.935
YML 2414/S	2 x 36w	1' x 4'	1223	-	300	-	80	-	0.383	0.915
YML 2424/S	2 x 36w	2' x 4'	1223	-	605	-	80	-	0.367	0.930
YML 3424/S	3 x 36w	2' x 4'	1223	-	605	-	80	-	0.602	0.914
YML 4424/S	4 x 36w	2' x 4'	1223	-	605	-	80	-	0.732	0.947

PHOTOMETRIC DATA

POLAR CURVE

UTILISATION FACTORS

LUMINAIRE: YML 2424/S
FLU. TUBE : 2 x 36w/T8, 3250 lm

L.O.R. 68.0% I_{max}(cd) 1911

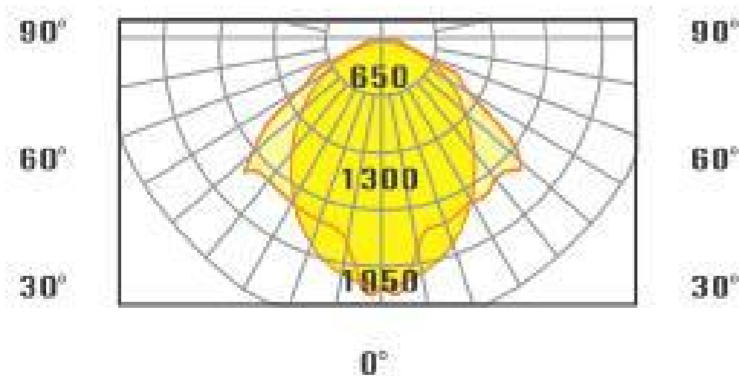

CO^{0°/180°} C90^{0°/270°}

AVERAGE BEAM ANGLE (30%) 125.8 DEG

MORE DATA ON PAGE 40 TO 44

REFLECTANCE

CEILING	0.8	0.8	0.8	0.7	0.7	0.7	0.5	0.5	0.5	0
WALL	0.7	0.5	0.3	0.7	0.5	0.3	0.7	0.5	0.3	0
FLOOR	0.2	0.2	0.2	0.2	0.2	0.2	0.2	0.2	0.2	0

Rm. Index	UTILISATION FACTORS IN PERCENT (%)										K(RI) x RCR = 5
K= 0.60	42	33	28	41	33	27	39	32	27	22	
0.80	49	40	35	48	40	34	46	39	34	28	
1.00	55	47	41	53	46	41	51	45	40	35	
1.25	59	52	47	58	51	47	55	50	46	40	
1.50	63	56	51	61	55	50	58	53	49	43	
2.00	67	61	57	65	60	56	62	58	55	49	
2.50	69	64	60	68	63	60	64	61	58	51	
3.00	71	67	64	70	66	63	66	63	61	54	
4.00	74	70	67	72	69	66	69	66	64	57	
5.00	75	72	70	73	71	68	70	68	66	59	

Room Index UF (TOTAL) Direct

According to DIN EN 13032-2 2004 Ceiling Mounted SHR_{NOM} = 1.25

MIRROR LOUVER FITTING type R

for recessed tee-bar ceiling

IP 20

CLASS 1

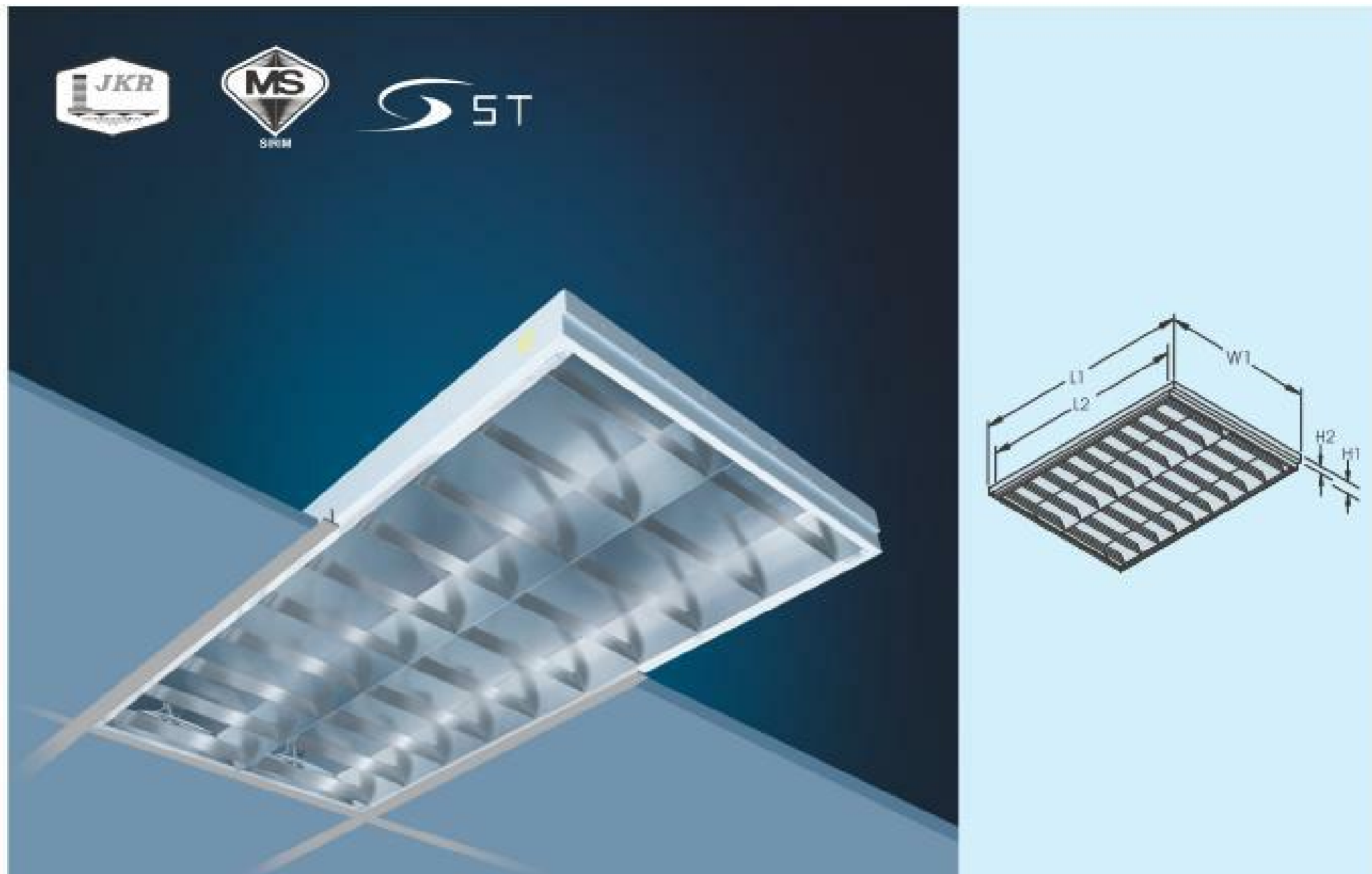

MODEL	FOR LAMP T8	IMPERIAL APPROX.	DIMENSION - mm						POWER AT 240vac	
			L1	L2	W1	W2	H1	H2	AMP.	P.F/ lag.
YML 2222/R	2 x 18w	2' x 2'	612	604	604	-	70	37	0.234	0.903
YML 3222/R	3 x 18w	2' x 2'	612	604	604	-	70	37	0.338	0.927
YML 4222/R	4 x 18w	2' x 2'	612	604	604	-	70	37	0.452	0.935
YML 2414/R	2 x 36w	1' x 4'	1223	1210	295	-	70	37	0.383	0.915
YML 2424/R	2 x 36w	2' x 4'	1223	1210	604	-	70	37	0.367	0.930
YML 3424/R	3 x 36w	2' x 4'	1223	1210	604	-	70	37	0.602	0.914
YML 4424/R	4 x 36w	2' x 4'	1223	1210	604	-	70	37	0.732	0.947

METRIC TYPE OF FITTINGS ARE AVAILABLE ON REQUEST

PHOTOMETRIC DATA

POLAR CURVE

UTILISATION FACTORS

LUMINAIRE: YML 2424/R
 FLU. TUBE : 2 x 36w/T8, 3250 lm

L.O.R. 68.0% I_{max}(cd) 1911

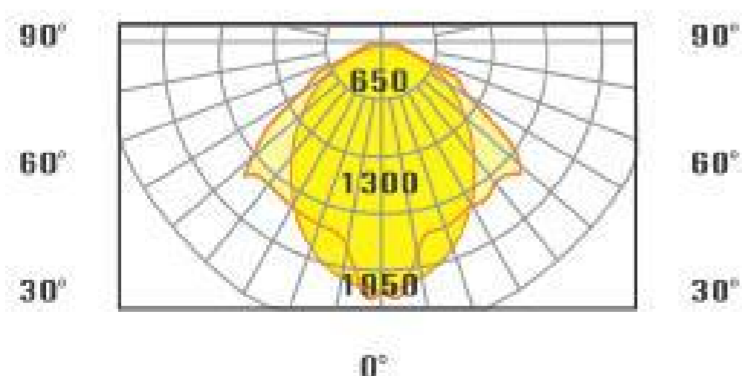

C0°/180°
 C90°/270°
 AVERAGE BEAM ANGLE (30%) 125.8 DEG

MORE DATA ON PAGE 40 TO 44

REFLECTANCE

CEILING	0.8	0.8	0.8	0.7	0.7	0.7	0.5	0.5	0.5	0
WALL	0.7	0.5	0.3	0.7	0.5	0.3	0.7	0.5	0.3	0
FLOOR	0.2	0.2	0.2	0.2	0.2	0.2	0.2	0.2	0.2	0

Rm. Index	UTILISATION FACTORS IN PERCENT (%)										K(RI) x RCR = 5
K= 0.60	42	33	28	41	33	27	39	32	27	22	
0.80	49	40	35	48	40	34	46	39	34	28	
1.00	55	47	41	53	46	41	51	45	40	35	
1.25	59	52	47	58	51	47	55	50	46	40	
1.50	63	56	51	61	55	50	58	53	49	43	
2.00	67	61	57	65	60	56	62	58	55	49	
2.50	69	64	60	68	63	60	64	61	58	51	
3.00	71	67	64	70	66	63	66	63	61	54	
4.00	74	70	67	72	69	66	69	66	64	57	
5.00	75	72	70	73	71	68	70	68	66	59	

Room Index UF (TOTAL) Direct
 According to DIN EN 13032-2 2004 Ceiling Mounted SHR_{NOM} = 1.25

MIRROR LOUVER FITTING type H

for recessed tee-bar ceiling

IP 20

CLASS 1



MODEL	FOR LAMP T8	IMPERIAL APPROX.	DIMENSION - mm						POWER AT 240vac	
			L1	L2	W1	W2	H1	H2	AMP.	PF/ lag.
YML 2222/H	2 x 18w	2' x 2'	612	604	604	-	70	37	0.234	0.903
YML 3222/H	3 x 18w	2' x 2'	612	604	604	-	70	37	0.338	0.927
YML 4222/H	4 x 18w	2' x 2'	612	604	604	-	70	37	0.452	0.935
YML 2424/H	2 x 36w	2' x 4'	1223	1210	604	-	70	37	0.367	0.930
YML 3424/H	3 x 36w	2' x 4'	1223	1210	604	-	70	37	0.602	0.914
YML 4424/H	4 x 36w	2' x 4'	1223	1210	604	-	70	37	0.732	0.947

FEATURE : FITTING WITH AIR OUT-PUT

PHOTOMETRIC DATA

POLAR CURVE

UTILISATION FACTORS

LUMINAIRE: YML 2424/H
 FLU. TUBE : 2 x 36w/T8, 3250 lm

L.O.R. 68.0% I_{max}(cd) 1911

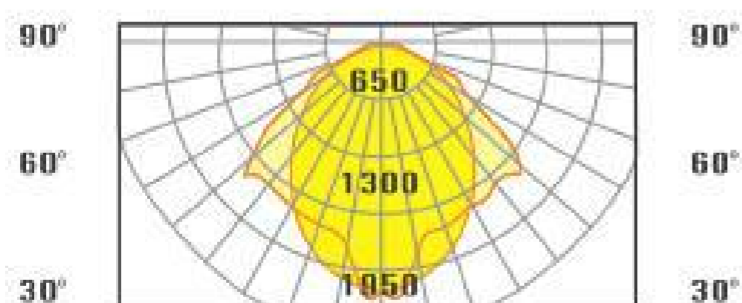

AVERAGE BEAM ANGLE (30%) 125.8 DEG

MORE DATA ON PAGE 40 TO 44

REFLECTANCE

CEILING	0.8	0.8	0.8	0.7	0.7	0.7	0.5	0.5	0.5	0
WALL	0.7	0.5	0.3	0.7	0.5	0.3	0.7	0.5	0.3	0
FLOOR	0.2	0.2	0.2	0.2	0.2	0.2	0.2	0.2	0.2	0

Rm. Index	UTILISATION FACTORS IN PERCENT (%)										K/(RI) x RCR = 5
K= 0.60	42	33	28	41	33	27	39	32	27	22	
0.80	49	40	35	48	40	34	46	39	34	28	
1.00	55	47	41	53	46	41	51	45	40	35	
1.25	59	52	47	58	51	47	55	50	46	40	
1.50	63	56	51	61	55	50	58	53	49	43	
2.00	67	61	57	65	60	56	62	58	55	49	
2.50	69	64	60	68	63	60	64	61	58	51	
3.00	71	67	64	70	66	63	66	63	61	54	
4.00	74	70	67	72	69	66	69	66	64	57	
5.00	75	72	70	73	71	68	70	68	66	59	

Room Index UF (TOTAL) Direct
 According to DIN EN 13032-2 2004 Ceiling Mounted SHR_{NOM} = 1.25

MIRROR LOUVER FITTING type RP

for recessed plaster ceiling

IP 20

CLASS 1

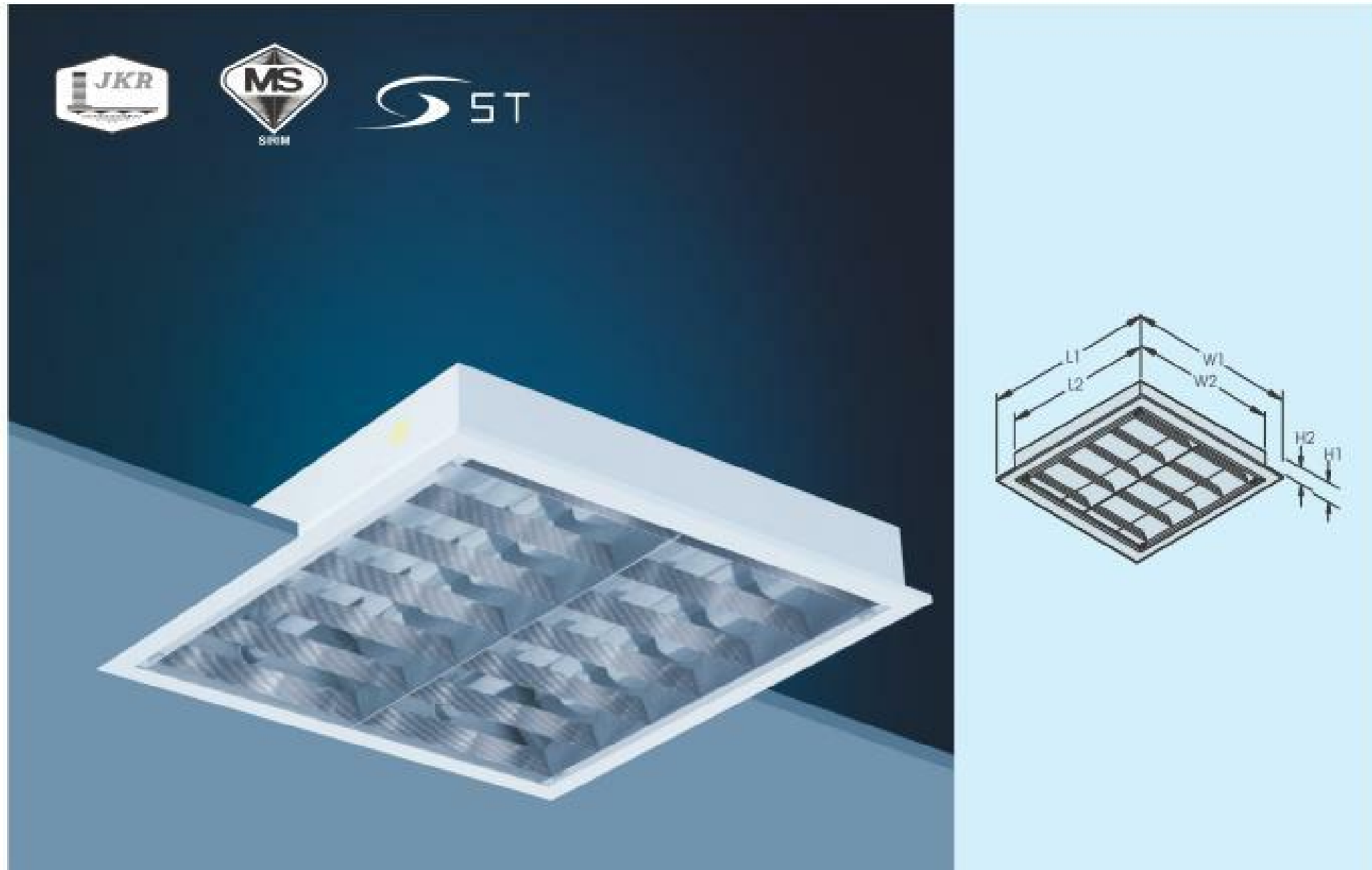

MODEL	FOR LAMP T8	IMPERIAL APPROX.	DIMENSION - mm						POWER AT 240vac	
			L1	L2	W1	W2	H1	H2	AMP.	PF/ lag.
YML 2222/RP	2 x 18w	2' x 2'	645	615	640	580	81	76	0.234	0.903
YML 3222/RP	3 x 18w	2' x 2'	645	615	640	580	81	76	0.338	0.927
YML 4222/RP	4 x 18w	2' x 2'	645	615	640	580	81	76	0.452	0.935
YML 2414/RP	2 x 36w	1' x 4'	1255	1225	330	270	81	76	0.383	0.915
YML 2424/RP	2 x 36w	2' x 4'	1255	1225	640	580	81	76	0.367	0.930
YML 3424/RP	3 x 36w	2' x 4'	1255	1225	640	580	81	76	0.602	0.914
YML 4424/RP	4 x 36w	2' x 4'	1255	1225	640	580	81	76	0.732	0.947

METRIC TYPE OF FITTINGS ARE AVAILABLE ON REQUEST

PHOTOMETRIC DATA

POLAR CURVE

UTILISATION FACTORS

LUMINAIRE: YML 2424/RP
 FLU. TUBE : 2 x 36w/T8, 3250 lm

L.O.R. 68.0% I_{max}(cd) 1911

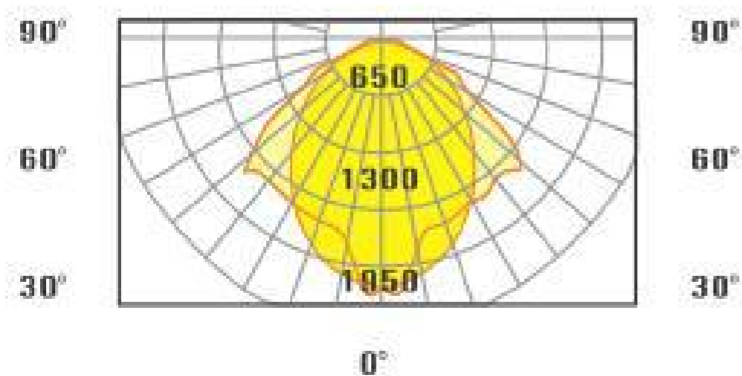

CO²/180° C90°/270°

AVERAGE BEAM ANGLE (30%) 125.8 DEG

MORE DATA ON PAGE 40 TO 44

REFLECTANCE

CEILING	0.8	0.8	0.8	0.7	0.7	0.7	0.5	0.5	0.5	0
WALL	0.7	0.5	0.3	0.7	0.5	0.3	0.7	0.5	0.3	0
FLOOR	0.2	0.2	0.2	0.2	0.2	0.2	0.2	0.2	0.2	0

Rm. Index	UTILISATION FACTORS IN PERCENT (%)										K(RI) x RCR = 5
K= 0.60	42	33	28	41	33	27	39	32	27	22	
0.80	49	40	35	48	40	34	46	39	34	28	
1.00	55	47	41	53	46	41	51	45	40	35	
1.25	59	52	47	58	51	47	55	50	46	40	
1.50	63	56	51	61	55	50	58	53	49	43	
2.00	67	61	57	65	60	56	62	58	55	49	
2.50	69	64	60	68	63	60	64	61	58	51	
3.00	71	67	64	70	66	63	66	63	61	54	
4.00	74	70	67	72	69	66	69	66	64	57	
5.00	75	72	70	73	71	68	70	68	66	59	

Room Index UF (TOTAL) Direct

According to DIN EN 13032-2 2004 Ceiling Mounted SHR_{NOM} = 1.25

CANLUX MIRROR LOUVER type S

for surface mounting

IP 20

CLASS 1

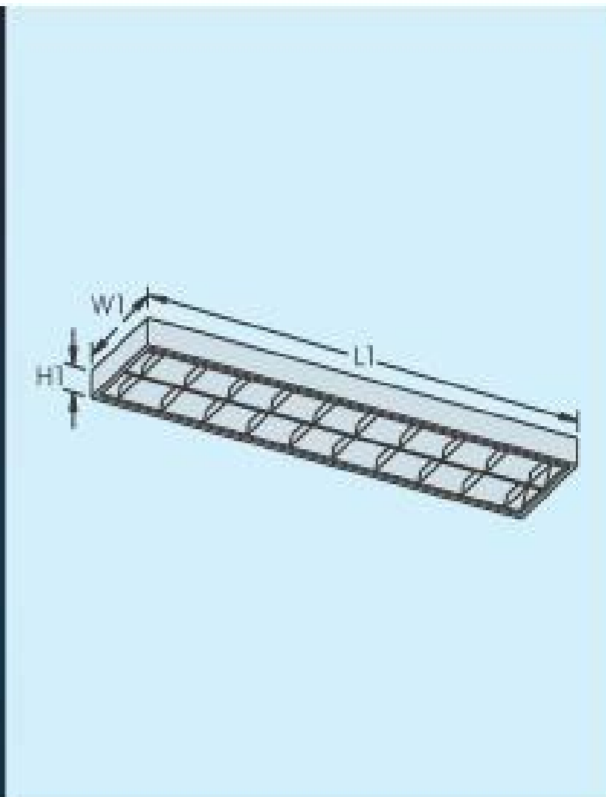

MODEL	FOR LAMP T8	IMPERIAL	DIMENSION - mm					
			L1	L2	W1	W2	H1	H2
ML 2222/S	2 x 18w	2' x 2'	615	-	605	-	80	-
ML 3222/S	3 x 18w	2' x 2'	615	-	605	-	80	-
ML 4222/S	4 x 18w	2' x 2'	615	-	605	-	80	-
ML 2414/S	2 x 36w	1' x 4'	1223	-	300	-	80	-
ML 2424/S	2 x 36w	2' x 4'	1223	-	605	-	80	-
ML 3424/S	3 x 36w	2' x 4'	1223	-	605	-	80	-
ML 4424/S	4 x 36w	2' x 4'	1223	-	605	-	80	-

CANLUX MIRROR LOUVER type RP

for recessed plaster ceiling

IP 20

CLASS 1

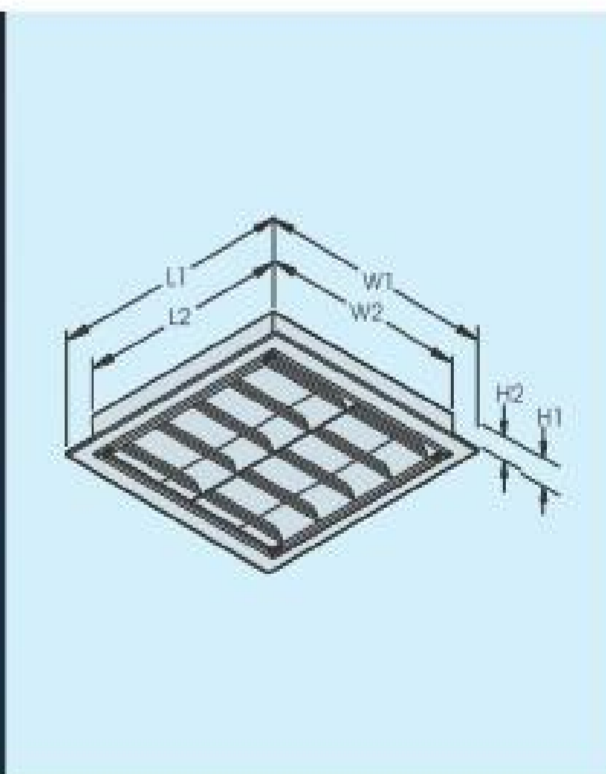

MODEL	FOR LAMP T8	IMPERIAL APPROX.	DIMENSION - mm					
			L1	L2	W1	W2	H1	H2
ML 2222/RP	2 x 18w	2' x 2'	645	615	640	580	81	76
ML 3222/RP	3 x 18w	2' x 2'	645	615	640	580	81	76
ML 4222/RP	4 x 18w	2' x 2'	645	615	640	580	81	76
ML 2414/RP	2 x 36w	1' x 4'	1255	1225	330	270	81	76
ML 2424/RP	2 x 36w	2' x 4'	1255	1225	640	580	81	76
ML 3424/RP	3 x 36w	2' x 4'	1255	1225	640	580	81	76
ML 4424/RP	4 x 36w	2' x 4'	1255	1225	640	580	81	76

CANLUX MIRROR LOUVER type R

for recessed tee-bar ceiling

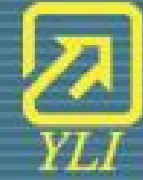

IP 20

CLASS 1

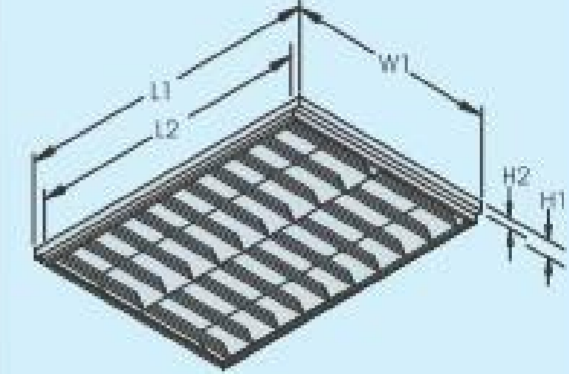

MODEL	FOR LAMP T8	IMPERIAL	DIMENSION - mm					
			L1	L2	W1	W2	H1	H2
ML 2222/R	2 x 18w	2' x 2'	612	604	604	-	70	37
ML 3222/R	3 x 18w	2' x 2'	612	604	604	-	70	37
ML 4222/R	4 x 18w	2' x 2'	612	604	604	-	70	37
ML 2414/R	2 x 36w	1' x 4'	1223	1210	295	-	70	37
ML 2424/R	2 x 36w	2' x 4'	1223	1210	604	-	70	37
ML 3424/R	3 x 36w	2' x 4'	1223	1210	604	-	70	37
ML 4424/R	4 x 36w	2' x 4'	1223	1210	604	-	70	37

METRIC SIZE OF FITTINGS ARE AVAILABLE ON REQUEST

CANLUX MIRROR LOUVER type E

for recessed tee-bar ceiling



IP 20

CLASS 1



FEATURE : D.I.Y DESIGN

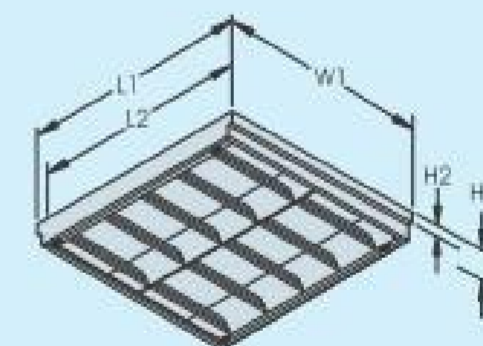

DIY PACKING
APPROX. 0.03 M³

MODEL	FOR LAMP T8	IMPERIAL APPROX.	DIMENSION - mm					
			L1	L2	W1	W2	H1	H2
E 2222	2 x 18w	2' x 2'	612	604	604	-	70	37
E 3222	3 x 18w	2' x 2'	612	604	604	-	70	37
E 4222	4 x 18w	2' x 2'	612	604	604	-	70	37
E 2424	2 x 36w	2' x 4'	1223	1210	604	-	70	37
E 3424	3 x 36w	2' x 4'	1223	1210	604	-	70	37
E 4424	4 x 36w	2' x 4'	1223	1210	604	-	70	37

DELUX MIRROR LOUVER type EF

for recessed tee-bar ceiling



IP 20

CLASS 1

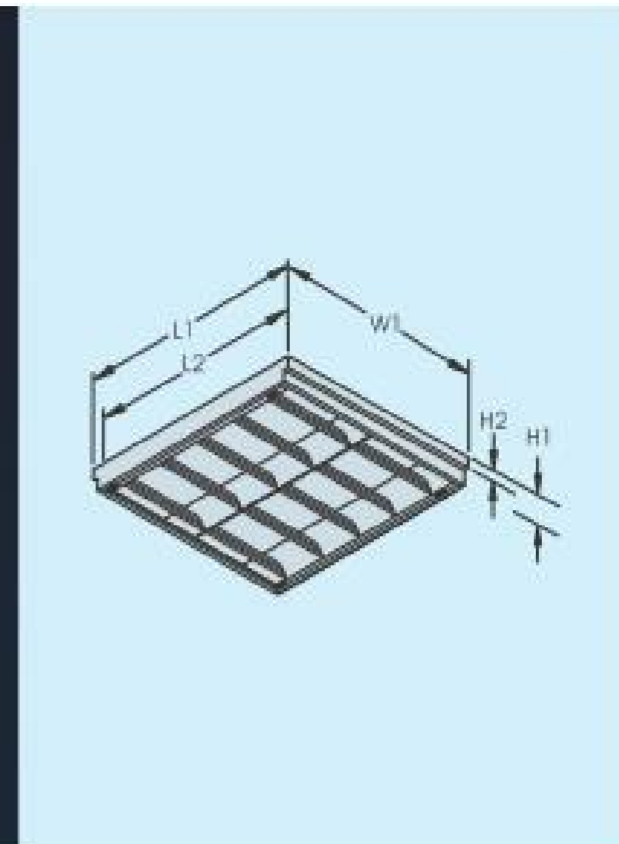

MODEL	FOR LAMP T8	IMPERIAL APPROX.	DIMENSION - mm					
			L1	L2	W1	W2	H1	H2
EF 2222	2 x 18w	2' x 2'	612	604	604	-	70	37
EF 3222	3 x 18w	2' x 2'	612	604	604	-	70	37
EF 4222	4 x 18w	2' x 2'	612	604	604	-	70	37
EF 2424	2 x 36w	2' x 4'	1223	1210	604	-	70	37
EF 3424	3 x 36w	2' x 4'	1223	1210	604	-	70	37
EF 4424	4 x 36w	2' x 4'	1223	1210	604	-	70	37

COMPACT MIRROR LOUVER

for recessed plaster ceiling



IP 20

CLASS 1

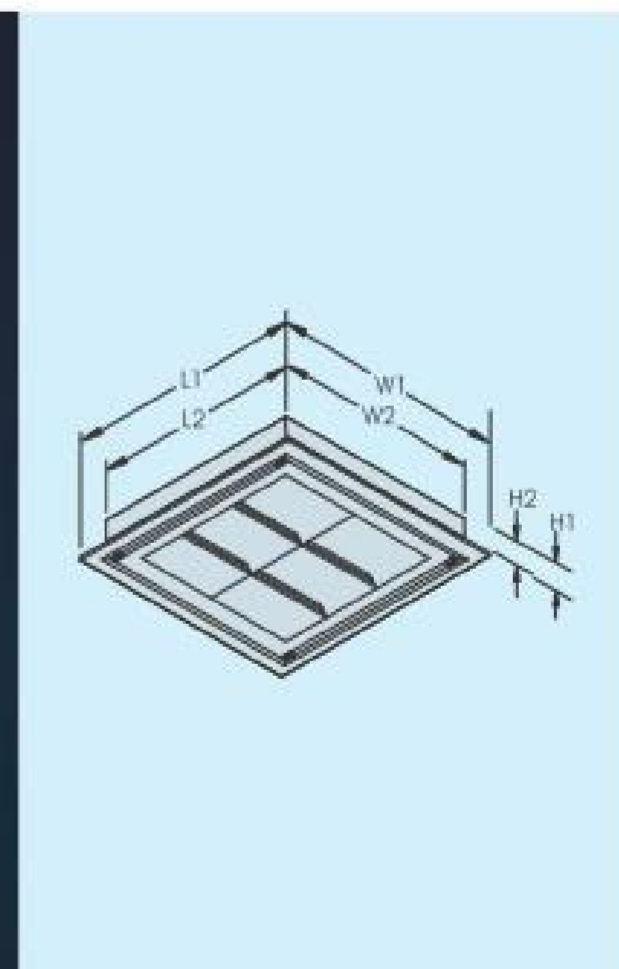

MODEL	FOR LAMP C.F.L.	IMPERIAL APPROX.	DIMENSION - mm					
			L1	L2	W1	W2	H1	H2
CM 211	2 x 11w PLS	1' x 1'	296	275	296	275	85	80
CM 218	2 x 18w PLL	1' x 1'	296	275	296	275	85	80
CM 226	2 x 26w PLC	1' x 1'	296	275	296	275	85	80

DOUBLE MIRROR LOUVER

for recessed or surface mounting

IP 20

CLASS 1



FOR RECESSED TEE-BAR CEILING type R

MODEL	FOR LAMP T8	IMPERIAL APPROX.	DIMENSION - mm					
			L1	L2	W1	W2	H1	H2
DM 2222/R	2 x 18w	2' x 2'	612	604	604	-	70	37
DM 3222/R	3 x 18w	2' x 2'	612	604	604	-	70	37
DM 4222/R	4 x 18w	2' x 2'	612	604	604	-	70	37
DM 2414/R	2 x 36w	1' x 4'	1223	1210	295	-	70	37
DM 2424/R	2 x 36w	2' x 4'	1223	1210	604	-	70	37
DM 3424/R	3 x 36w	2' x 4'	1223	1210	604	-	70	37
DM 4424/R	4 x 36w	2' x 4'	1223	1210	604	-	70	37

METRIC SIZE OF FITTINGS ARE AVAILABLE ON REQUEST

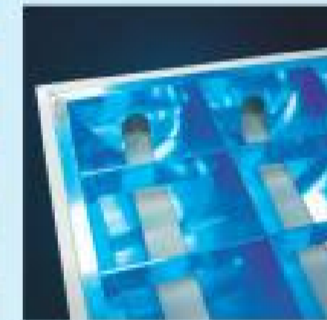

FOR RECESSED PLASTER CEILING type RP

MODEL	FOR LAMP T8	IMPERIAL APPROX.	DIMENSION - mm					
			L1	L2	W1	W2	H1	H2
DM 2222/RP	2 x 18w	2' x 2'	645	614	638	580	80	74
DM 3222/RP	3 x 18w	2' x 2'	645	614	638	580	80	74
DM 4222/RP	4 x 18w	2' x 2'	645	614	638	580	80	74
DM 2414/RP	2 x 36w	1' x 4'	1258	1224	332	273	80	74
DM 2424/RP	2 x 36w	2' x 4'	1258	1224	638	580	80	74
DM 3424/RP	3 x 36w	2' x 4'	1258	1224	638	580	80	74
DM 4424/RP	4 x 36w	2' x 4'	1258	1224	638	580	80	74



FOR SURFACE MOUNTING type S

MODEL	FOR LAMP T8	IMPERIAL APPROX.	DIMENSION - mm					
			L1	L2	W1	W2	H1	H2
DM 2222/S	2 x 18w	2' x 2'	615	-	605	-	80	-
DM 3222/S	3 x 18w	2' x 2'	615	-	605	-	80	-
DM 4222/S	4 x 18w	2' x 2'	615	-	605	-	80	-
DM 2414/S	2 x 36w	1' x 4'	1223	-	300	-	80	-
DM 2424/S	2 x 36w	2' x 4'	1223	-	605	-	80	-
DM 3424/S	3 x 36w	2' x 4'	1223	-	605	-	80	-
DM 4424/S	4 x 36w	2' x 4'	1223	-	605	-	80	-



INDIRECT FITTING type A

for recessed plaster ceiling



IP 20

CLASS 1

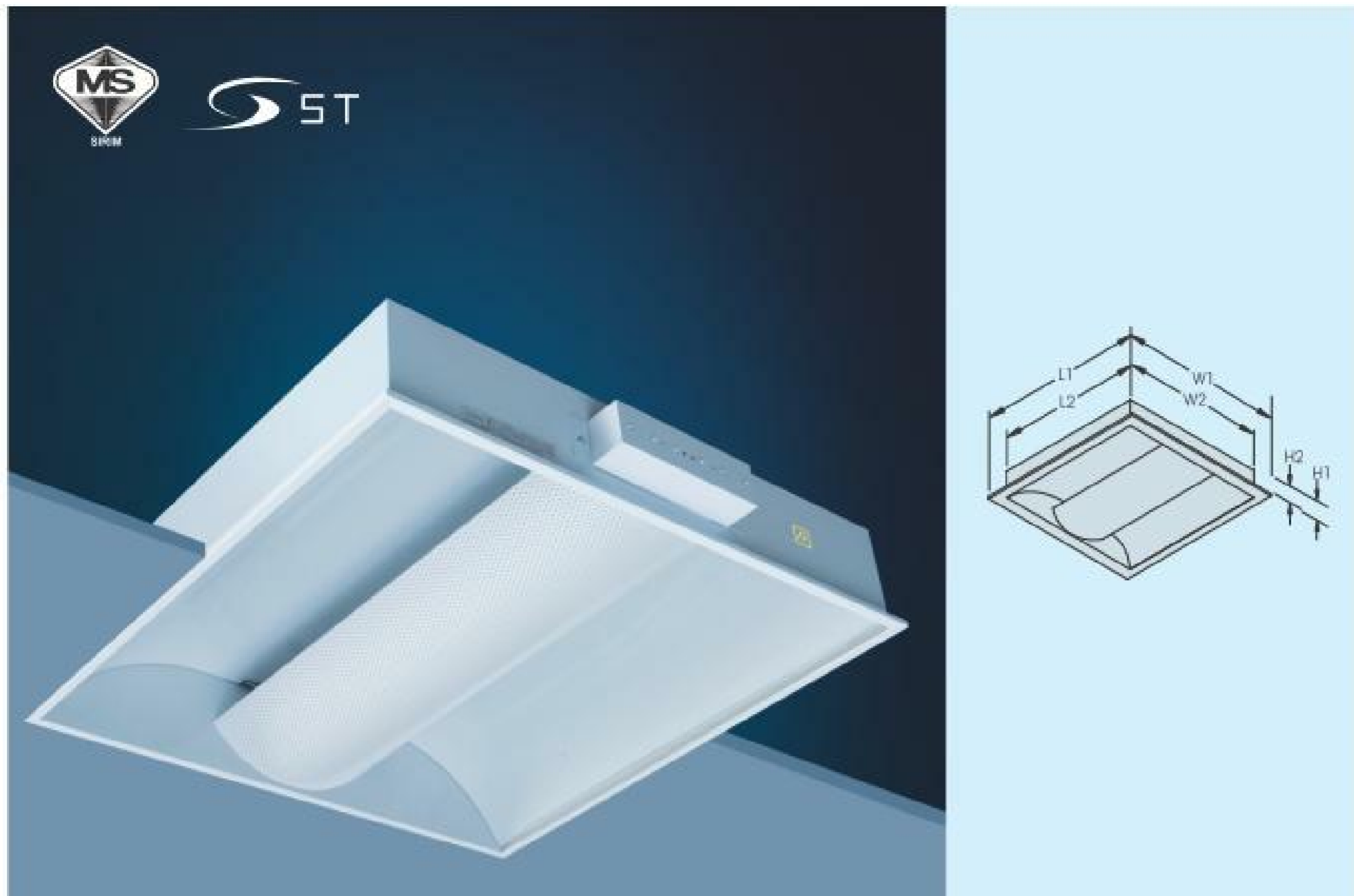

SPECIFICATION : THE DIFFUSER IS FABRICATED FROM PERFORATED MILD STEEL.
FEATURE : GLARE FREE
 MULTIPLE LIGHT SOURCE i.e. T5, T8, & COMPACT FLUORESCENT LAMP.

MODEL	FOR LAMP T8	IMPERIAL APPROX.	DIMENSION - mm						POWER AT 240vac	
			L1	L2	W1	W2	H1	H2	AMP.	P.F/ lag.
YID 218/A	2 x 18w	2' x 2'	604	584	604	584	115	110	0.569	0.903
YID 318/A	3 x 18w	2' x 2'	604	584	604	584	115	110	0.401	0.912
YID 236/A	2 x 36w	2' x 4'	1210	1190	604	584	115	110	0.401	0.915
YID 336/A	3 x 36w	2' x 4'	1210	1190	604	584	115	110	0.597	0.914

OPTIONAL SIZE OF FITTINGS FOR OTHER LIGHT SOURCE ARE AVAILABLE ON REQUEST

PHOTOMETRIC DATA

POLAR CURVE

UTILISATION FACTORS

LUMINAIRE: YID 236/A
FLU. TUBE : 2 x 36w/T8, 3250 lm

L.O.R. 36.4% **Imax(cd) 713.4**

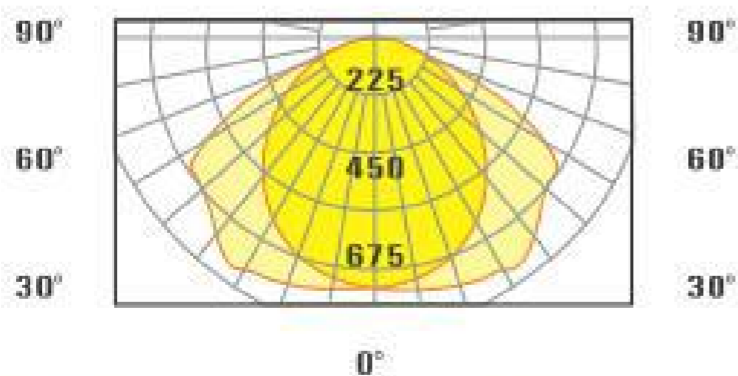

CO°/180° **C90°/270°**

AVERAGE BEAM ANGLE (30%) 137.9 DEG

MORE DATA ON PAGE 40 TO 44

REFLECTANCE

CEILING	0.8	0.8	0.8	0.7	0.7	0.7	0.5	0.5	0.5	0
WALL	0.7	0.5	0.3	0.7	0.5	0.3	0.7	0.5	0.3	0
FLOOR	0.2	0.2	0.2	0.2	0.2	0.2	0.2	0.2	0.2	0

Rm. Index	UTILISATION FACTORS IN PERCENT (%)										K/(RI) x RCR = 5
K= 0.60	21	16	13	21	16	13	20	16	13	10	
0.80	25	20	17	24	20	17	23	19	16	13	
1.00	28	24	20	27	23	20	26	22	20	17	
1.25	31	26	23	30	26	23	28	25	23	19	
1.50	32	29	26	32	28	25	30	27	25	21	
2.00	35	32	29	34	31	29	32	30	28	24	
2.50	36	33	31	35	33	31	34	31	30	26	
3.00	37	35	33	37	34	32	35	33	31	28	
4.00	39	37	35	38	36	34	36	35	33	30	
5.00	40	38	36	39	37	36	37	36	34	31	

Room Index UF (TOTAL) Direct

According to DIN EN 13032-2 2004 Ceiling Mounted SHR NOM = 1.25

INDIRECT FITTING type V

for recessed plaster ceiling



IP 20

CLASS 1

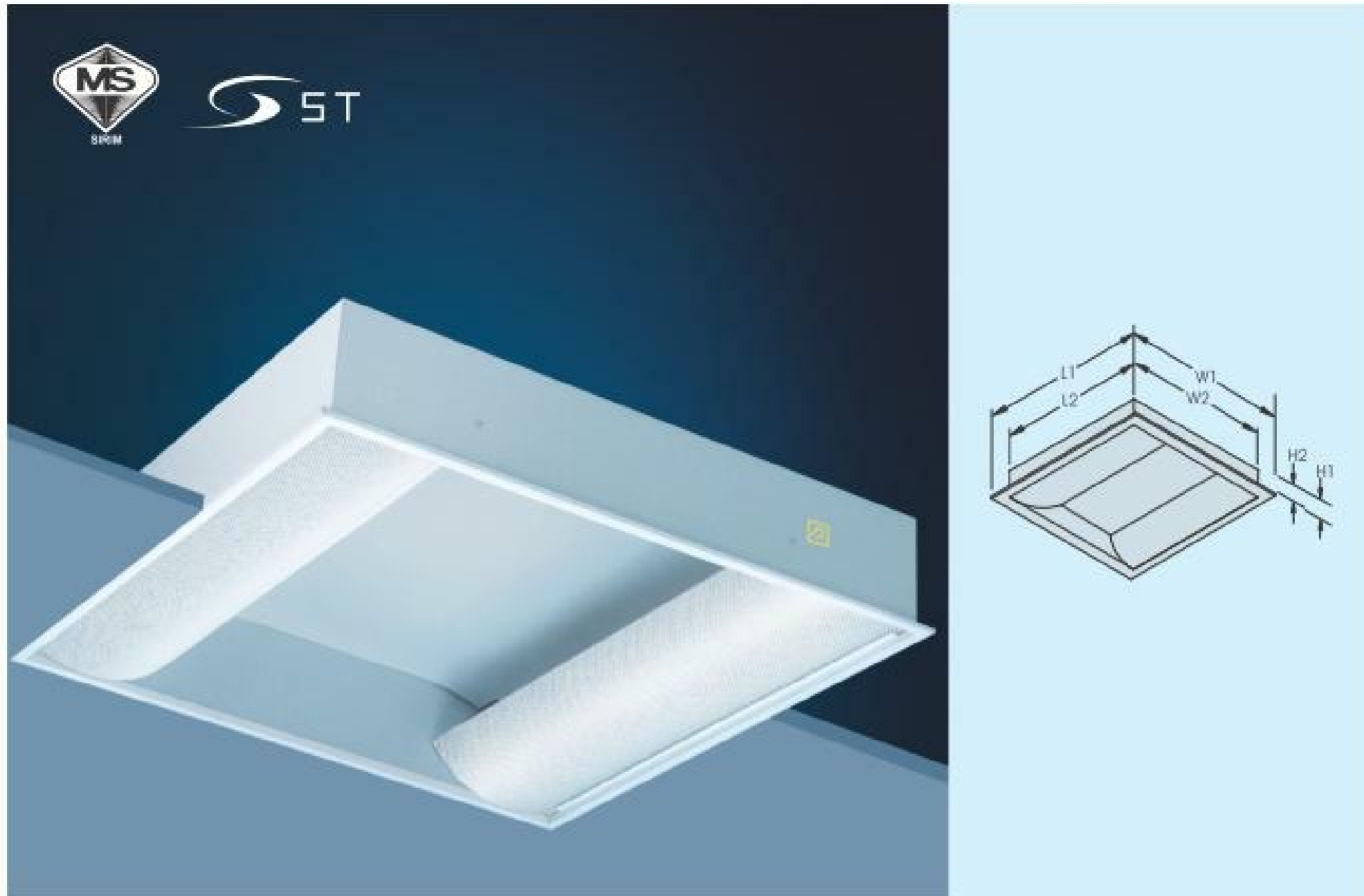

SPECIFICATION : THE DIFFUSER IS FABRICATED FROM PERFORATED MILD STEEL.
FEATURE : GLARE FREE
 MULTIPLE LIGHT SOURCE i.e. T5, T8, & COMPACT FLUORESCENT LAMP.

MODEL	FOR LAMP T8	IMPERIAL APPROX.	DIMENSION - mm						POWER AT 240vac	
			L1	L2	W1	W2	H1	H2	AMP.	PF/ lag.
YID 218/V	2 x 18w	2' x 2'	604	584	604	584	115	110	0.221	0.903
YID 418/V	4 x 18w	2' x 2'	604	584	604	584	115	110	0.452	0.935
YID 236/V	2 x 36w	2' x 4'	1210	1190	604	584	115	110	0.358	0.929
YID 436/V	4 x 36w	2' x 4'	1210	1190	604	584	115	110	0.732	0.947

OPTIONAL SIZE OF FITTINGS FOR OTHER LIGHT SOURCE ARE AVAILABLE ON REQUEST

PHOTOMETRIC DATA

POLAR CURVE

UTILISATION FACTORS

LUMINAIRE: YID 236/V
FLU. TUBE : 2 x 36w/T8, 3250 lm

L.O.R. 35.6% **Imax(cd) 698.6**

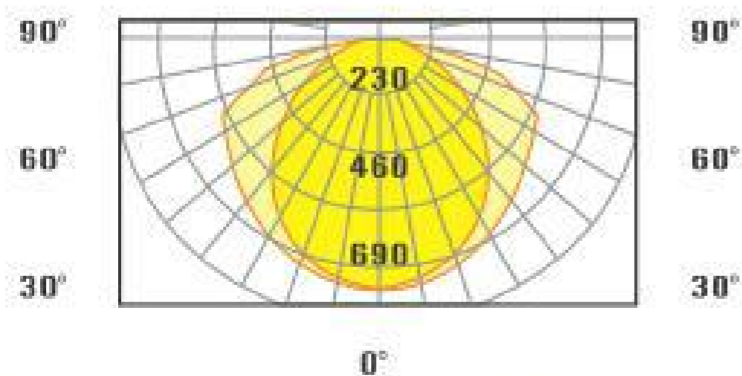

C0°/180° **C90°/270°**

AVERAGE BEAM ANGLE (30%) 145.1 DEG

MORE DATA ON PAGE 40 TO 44

REFLECTANCE

CEILING	0.8	0.8	0.8	0.7	0.7	0.7	0.5	0.5	0.5	0
WALL	0.7	0.5	0.3	0.7	0.5	0.3	0.7	0.5	0.3	0
FLOOR	0.2	0.2	0.2	0.2	0.2	0.2	0.2	0.2	0.2	0

Rm. Index	UTILISATION FACTORS IN PERCENT (%)										K(RI) x RCR = 5
K= 0.60	21	16	13	20	16	13	19	15	13	10	
0.80	24	20	16	24	19	16	22	19	16	13	
1.00	27	23	20	26	22	19	25	22	19	16	
1.25	30	25	22	29	25	22	27	24	22	18	
1.50	31	27	25	31	27	24	29	26	24	20	
2.00	34	30	28	33	30	27	31	29	27	23	
2.50	35	32	30	34	32	29	32	30	28	25	
3.00	36	34	32	35	33	31	34	32	30	26	
4.00	38	36	34	37	35	33	35	33	32	28	
5.00	39	37	35	38	36	35	36	35	33	30	

Room Index UF (TOTAL) Direct

According to DIN EN 13032-2 2004 Ceiling Mounted SHR NOM = 1.25

INDIRECT FITTING type SG

for surface mounting



IP 20

CLASS 1

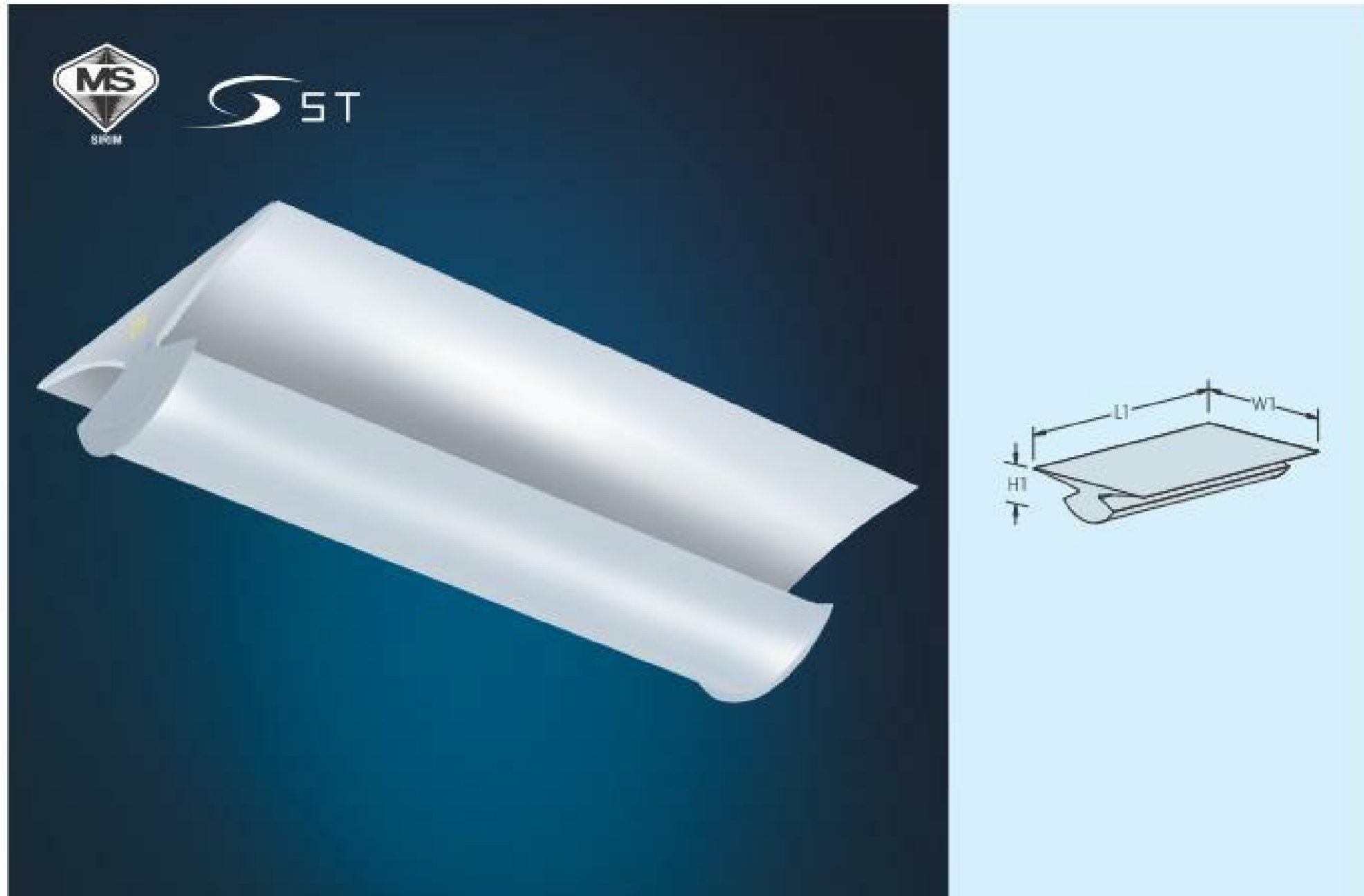

SPECIFICATION : THE DIFFUSER IS FABRICATED FROM PERFORATED MILD STEEL.
FEATURE : GLARE FREE
 MULTIPLE LIGHT SOURCE T5, T8, & COMPACT FLUORESCENT LAMP.

MODEL	FOR LAMP T8	IMPERIAL APPROX.	DIMENSION - mm						POWER AT 240vac	
			L1	L2	W1	W2	H1	H2	AMP.	P.F/ lag.
YID 218/SG	2 x 18w	1.7' x 2'	620	-	400	-	140	-	0.309	0.903
YID 318/SG	3 x 18w	1.7' x 2'	620	-	400	-	140	-	0.372	0.912
YID 236/SG	2 x 36w	1.7' x 4'	1230	-	400	-	140	-	0.388	0.915
YID 336/SG	3 x 36w	1.7' x 4'	1230	-	400	-	140	-	0.596	0.914

OPTIONAL SIZE OF FITTINGS FOR OTHER LIGHT SOURCE ARE AVAILABLE ON REQUEST

PHOTOMETRIC DATA

POLAR CURVE

UTILISATION FACTORS

LUMINAIRE: YID 236/SG
FLU. TUBE : 2 x 36w/T8, 3250 lm

L.O.R. 39.5% **Imax(cd) 619.3**

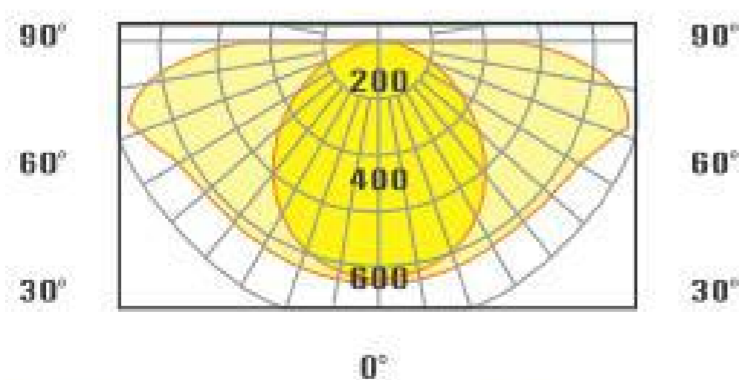

C0°/180° **C90°/270°**

AVERAGE BEAM ANGLE (30%) 157.0 DEG

MORE DATA ON PAGE 40 TO 44

REFLECTANCE

CEILING	0.8	0.8	0.8	0.7	0.7	0.7	0.5	0.5	0.5	0
WALL	0.7	0.5	0.3	0.7	0.5	0.3	0.7	0.5	0.3	0
FLOOR	0.2	0.2	0.2	0.2	0.2	0.2	0.2	0.2	0.2	0

Rm. Index	UTILISATION FACTORS IN PERCENT (%)										K(RI) x RCR = 5
K= 0.60	21	15	12	21	15	12	19	15	11	8	
0.80	25	19	15	24	19	15	23	18	14	11	
1.00	28	22	18	27	21	18	25	21	17	13	
1.25	30	25	21	29	24	21	27	23	20	16	
1.50	32	27	23	31	26	23	29	25	22	18	
2.00	35	30	27	34	30	26	32	28	25	21	
2.50	37	32	29	35	32	28	33	30	27	23	
3.00	38	34	31	37	33	30	35	32	29	25	
4.00	40	37	34	39	36	33	36	34	32	27	
5.00	41	38	36	40	37	35	38	35	34	29	

Room Index UF (TOTAL) Direct

According to DIN EN 13032-2 2004 Ceiling Mounted SHR NOM = 1.25

INDIRECT FITTING type FSG

for surface mounting

IP 20

CLASS 1

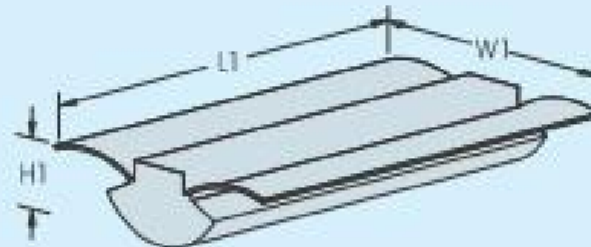

SPECIFICATION : THE DIFFUSER IS FABRICATED FROM PERFORATED MILD STEEL.
FEATURE : GLARE FREE
 MULTIPLE LIGHT SOURCE T5, T8, & COMPACT FLUORESCENT LAMP.

MODEL	FOR LAMP T8	IMPERIAL APPROX.	DIMENSION - mm						POWER AT 240vac	
			L1	L2	W1	W2	H1	H2	AMP.	P.F/ lag.
YID 218/FSG	2 x 18w	1.7' x 2'	620	-	400	-	140	-	0.224	0.950
YID 318/FSG	3 x 18w	1.7' x 2'	620	-	400	-	140	-	0.372	0.912
YID 236/FSG	2 x 36w	1.7' x 4'	1230	-	400	-	140	-	0.401	0.915
YID 336/FSG	3 x 36w	1.7' x 4'	1230	-	400	-	140	-	0.584	0.914

OPTIONAL SIZE OF FITTINGS FOR OTHER LIGHT SOURCE ARE AVAILABLE ON REQUEST

PHOTOMETRIC DATA

POLAR CURVE

UTILISATION FACTORS

LUMINAIRE: YID 236/FSG
FLU. TUBE : 2 x 36w/T8, 3250 lm

L.O.R. 46.9% **Imax(cd) 904.9**

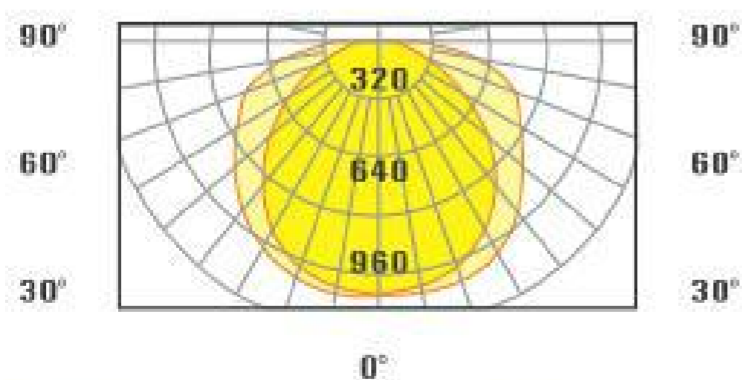

CO°/180° **C90°/270°**

AVERAGE BEAM ANGLE (30%) 149.2 DEG

MORE DATA ON PAGE 40 TO 44

REFLECTANCE

CEILING	0.8	0.8	0.8	0.7	0.7	0.7	0.5	0.5	0.5	0
WALL	0.7	0.5	0.3	0.7	0.5	0.3	0.7	0.5	0.3	0
FLOOR	0.2	0.2	0.2	0.2	0.2	0.2	0.2	0.2	0.2	0

Rm. Index	UTILISATION FACTORS IN PERCENT (%)										K/(RI) x RCR = 5
K= 0.60	27	21	17	27	21	17	25	20	17	13	
0.80	32	26	21	31	25	21	29	24	21	17	
1.00	36	30	25	35	29	25	33	28	25	20	
1.25	39	33	29	38	33	29	36	31	28	24	
1.50	41	36	32	40	35	31	38	34	31	26	
2.00	44	40	36	43	39	35	41	37	34	30	
2.50	46	42	39	45	41	38	42	39	37	32	
3.00	47	44	41	46	43	40	44	41	39	34	
4.00	49	46	44	48	45	43	46	43	41	36	
5.00	50	48	46	49	47	45	47	45	43	38	

Room Index UF (TOTAL) Direct

According to DIN EN 13032-2 2004 Ceiling Mounted SHR NOM = 1.25

IP 20

CLASS 1

INDIRECT LIGHT type A

for recessed plaster ceiling

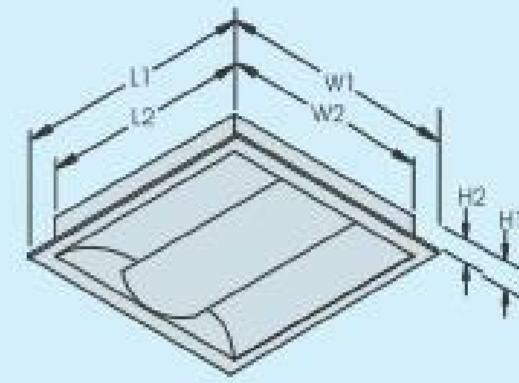

MODEL	FOR LAMP T8	IMPERIAL APPROX.	DIMENSION - mm					
			L1	L2	W1	W2	H1	H2
ID 220/A	2 x 18w	2' x 2'	604	584	604	584	115	110
ID 320/A	3 x 18w	2' x 2'	604	584	604	584	115	110
ID 240/A	2 x 36w	2' x 4'	1210	1190	604	584	115	110
ID 340/A	3 x 36w	2' x 4'	1210	1190	604	584	115	110

IP 20

CLASS 1

INDIRECT LIGHT type V

for recessed plaster ceiling

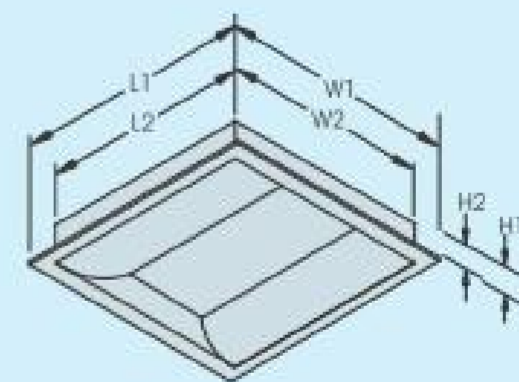

MODEL	FOR LAMP T8	IMPERIAL APPROX.	DIMENSION - mm					
			L1	L2	W1	W2	H1	H2
ID 220/V	2 x 18w	2' x 2'	604	584	604	584	115	110
ID 420/V	4 x 18w	2' x 2'	604	584	604	584	115	110
ID 240/V	2 x 36w	2' x 4'	1210	1190	604	584	115	110
ID 440/V	4 x 36w	2' x 4'	1210	1190	604	584	115	110

INDIRECT LIGHT type SG

for surface mounting



IP 20

CLASS 1

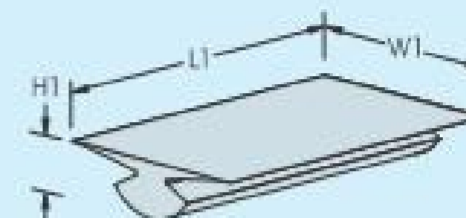

MODEL	FOR LAMP T8	IMPERIAL APPROX.	DIMENSION - mm					
			L1	L2	W1	W2	H1	H2
ID 220/SG	2 x 18w	1.7' x 2'	620	-	400	-	140	-
ID 320/SG	3 x 18w	1.7' x 2'	620	-	400	-	140	-
ID 240/SG	2 x 36w	1.7' x 4'	1230	-	400	-	140	-
ID 340/SG	3 x 36w	1.7' x 4'	1230	-	400	-	140	-

INDIRECT LIGHT type M

for recessed mounting



IP 20

CLASS 1

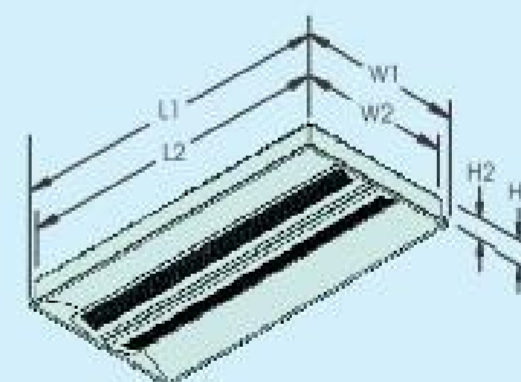

FEATURE : PERFORATED METAL-DIFFUSER IS BUILT TO OPEN & CLOSE MAGNETICALLY

MODEL	FOR LAMP T5	IMPERIAL APPROX.	DIMENSION - mm					
			L1	L2	W1	W2	H1	H2
ID 214/M	2 x 14w	2' x 2'	605	590	605	579	90	85
ID 221/M	2 x 21w	2' x 3'	905	890	605	579	90	85
ID 228/M	2 x 28w	2' x 4'	1211	1203	605	579	90	85
ID 235/M	2 x 35w	2' x 5'	1511	1503	605	579	90	85

HINGED DIFFUSER FITTING

for recessed mounting

IP 20

CLASS 1



HD 226



HD 2222/RP



DIFFUSER : ACRYLIC PRISMATIC : HDxxxx/xx/PT OR OPAL : HDxxxx/xx/OP

FOR CFL LAMP - RECESSED PLASTER CEILING - OPEN & CLOSE BY CURVED SPRING 'V'

MODEL	FOR LAMP	IMPERIAL APPROX.	DIMENSION - mm					
			L1	L2	W1	W2	H1	H2
HD 218	2 x 18w PLL	1' x 1'	300	270	300	270	81	76
HD 318	3 x 18w PLL	1' x 1'	300	270	300	270	81	76
HD 226	2 x 26w PLC	1' x 1'	300	270	300	270	81	76



type R - FOR T8 LAMP - RECESSED TEE-BAR CEILING - OPEN & CLOSE BY SPRING BOLT

MODEL	FOR LAMP	IMPERIAL APPROX.	DIMENSION - mm					
			L1	L2	W1	W2	H1	H2
HD 2222/R	2 x 18w	2' x 2'	612	604	604	-	81	37
HD 3222/R	3 x 18w	2' x 2'	612	604	604	-	81	37
HD 4222/R	4 x 18w	2' x 2'	612	604	604	-	81	37
HD 2414/R	2 x 36w	1' x 4'	1223	1210	295	-	81	37
HD 2424/R	2 x 36w	2' x 4'	1223	1210	604	-	81	37
HD 3424/R	3 x 36w	2' x 4'	1223	1210	604	-	81	37
HD 4424/R	4 x 36w	2' x 4'	1223	1210	604	-	81	37



type RP - FOR T8 LAMP - RECESSED PLASTER CEILING - OPEN & CLOSE BY SPRING BOLT

MODEL	FOR LAMP	IMPERIAL APPROX.	DIMENSION - mm					
			L1	L2	W1	W2	H1	H2
HD 2222/RP	2 x 18w	2' x 2'	645	615	640	580	81	76
HD 3222/RP	3 x 18w	2' x 2'	645	615	640	580	81	76
HD 4222/RP	4 x 18w	2' x 2'	645	615	640	580	81	76
HD 2414/RP	2 x 36w	1' x 4'	1255	1225	330	270	81	76
HD 2424/RP	2 x 36w	2' x 4'	1255	1225	640	580	81	76
HD 3424/RP	3 x 36w	2' x 4'	1255	1225	640	580	81	76
HD 4424/RP	4 x 36w	2' x 4'	1255	1225	640	580	81	76

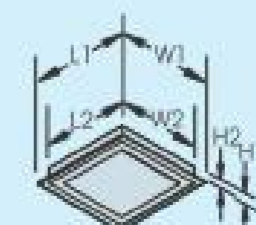

SUSPENSION SYSTEM

IP 20

CLASS 1



MODEL	LENGTH OF SUSPENSION	CONTENT - EACH SET
SUSPENSION CEILING CAP		
SCC 305	305 mm / 12"	2 x ALUMINIUM CEILING CAP, 2 x STAINLESS STEEL CABLE & 1 x PVC INSULATED WIRE 3 CORE.
SCC 460	460 mm / 18"	
SCC 610	610 mm / 24"	
SCC 990	990 mm / 39"	
SUSPENSION ROD		
SSR 305	305 mm / 12"	2 x MILD STEEL TUBE WITH LOCK NUT, 1 x MILD STEEL MOUNTING BASE & 1 x MILD STEEL CHANNEL.
SSR 460	460 mm / 18"	
SSR 610	610 mm / 24"	

REFLECTOR

for bare channel fitting & batten fitting

IP 20

CLASS 1



MODEL	FOR FITTING & LENGTH
FULL METAL REFLECTOR	
MER 120	1 x 18w 2'
MER 220	2 x 18w 2'
MER 140	1 x 36w 4'
MER 240	2 x 36w 4'
FULL MIRROR REFLECTOR	
MIR 120	1 x 18w 2'
MIR 220	2 x 18w 2'
MIR 140	1 x 36w 4'
MIR 240	2 x 36w 4'

MODEL	FOR FITTING & LENGTH
ANGLE METAL REFLECTOR	
MER 120 A	1 x 18w 2'
MER 220 A	2 x 18w 2'
MER 140 A	1 x 36w 4'
MER 240 A	2 x 36w 4'
ANGLE MIRROR REFLECTOR	
MIR 120 A	1 x 18w 2'
MIR 220 A	2 x 18w 2'
MIR 140 A	1 x 36w 4'
MIR 240 A	2 x 36w 4'

LIGHT COLOR • SPECTRAL ENERGY DISTRIBUTION

Light Color and Color Temperature

Among the light colors that can be found in light sources there are ones with red, light blue, and many other various colors. The "color temperature" expresses the color of light in numeric form. An object (black body) gives off light as it is heated, the color of the light gradually changes from red to yellow to white to light blue. There is a relationship between the temperature (absolute temperature K, Kelvin units) and the color. The color temperature expresses the color of light with temperature, using this relationship. The advantage of the color temperature index is that the color of light can be expressed in connection with human vision with just one number as shown in the chart to the right.

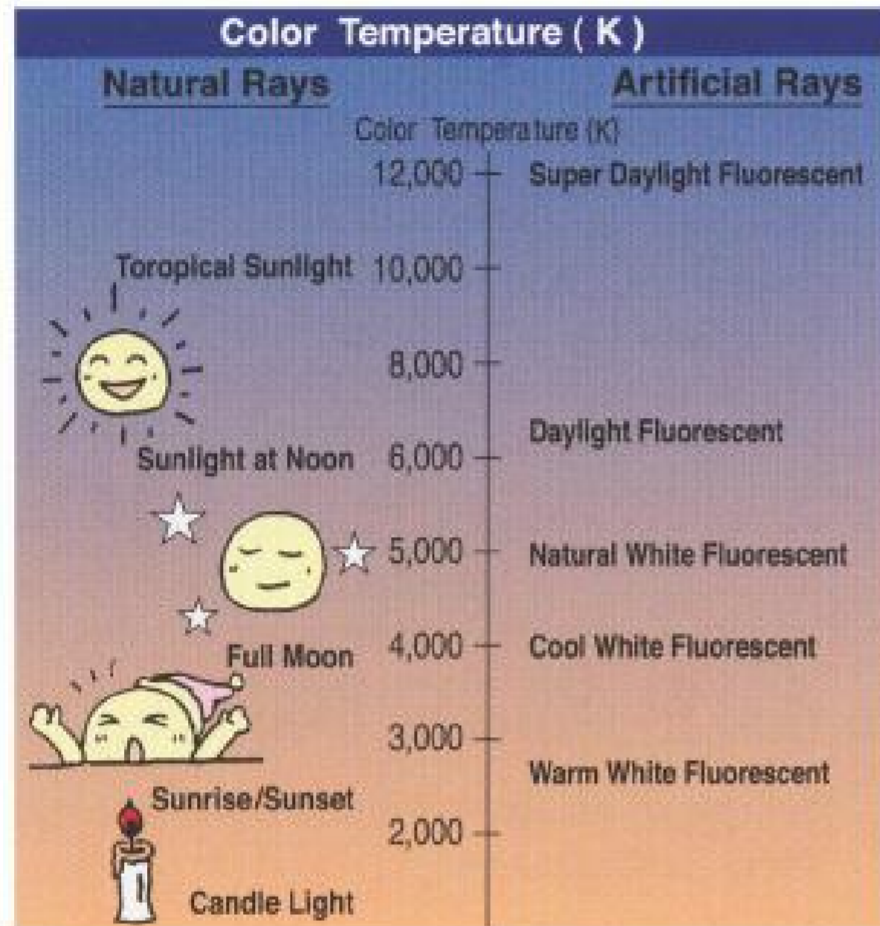

Spectral Energy Distribution of Fluorescent Lamps

The spectral energy distribution graphs shown below give the luminous energy for each wavelength from the various types of lamps. The curves in the graphs indicate the continuous spectrum of the luminescence from the fluorescent material and the bars indicate the spectral lines of luminescence from mercury.

3 Band Daylight

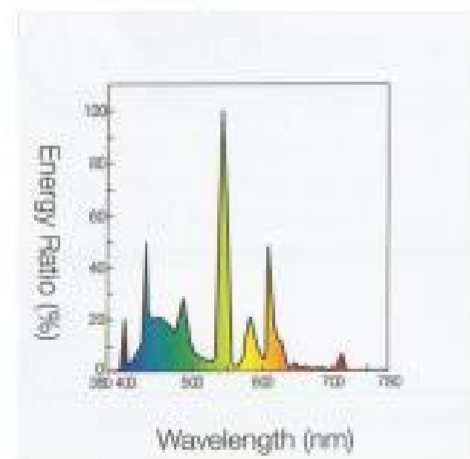

Daylight (D)

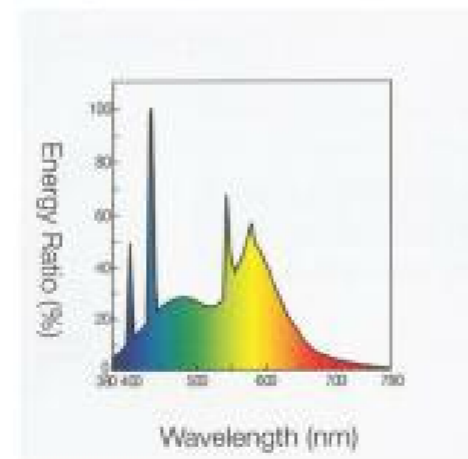

Warm White (WW)

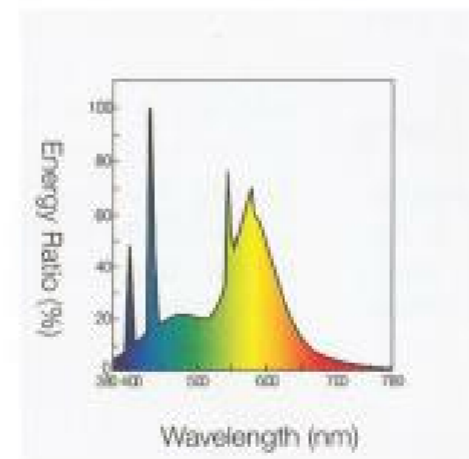

Cool White (W)

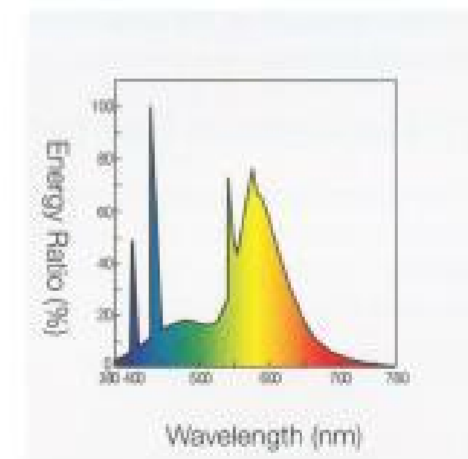

3 Band Super Daylight (12,000K)

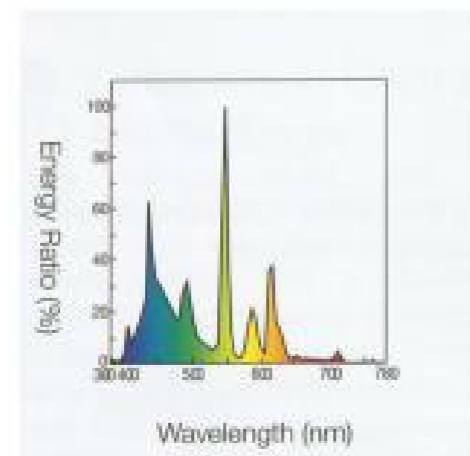

Super Daylight (12,000K)

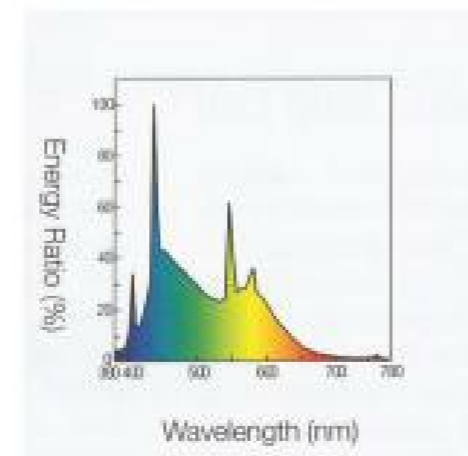

Black Light (BL)

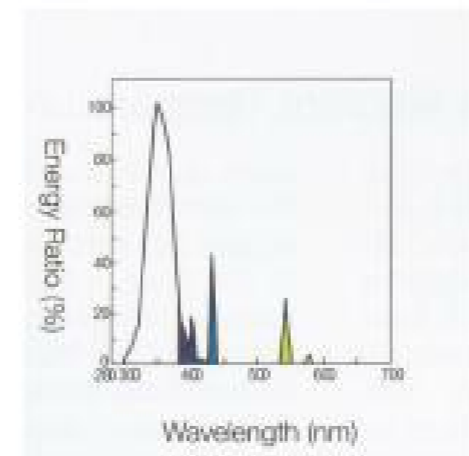

Black Light Blue (BLB)

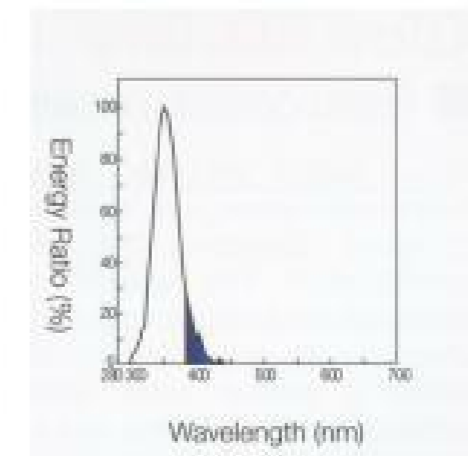

THREE BAND PHOSPHOR TYPE FLUORESCENT LAMPS

With 3 types of phosphor colored blue, green and red, color performance (the way that the color looks) is vastly improved and color is reproduced vividly. Color performance, where the quality of light has become luxuriant, is obtained by these lamps with the ideal conditions to meet your needs for high quality, authenticity and nature.



Product Order Code	Colour Temperature(K)	Watts (W)	Bulb Shape	Bulb Dia.(mm)	Bulb Length(mm)	Base	Rated Lamp Current(A)	Initial Lumens(lm)	Average Life(h)	Colour Rendering Index(Ra)	Std.Pkg. Qty	Colour Description
STRAIGHT TYPE												
FL10EX-D-Z	6,700	10	T-8	25.5	330.0	G13	0.230	520	7,500	88	10	3-Band Daylight
FL10EX-N-Z	5,000	10	T-8	25.5	330.0	G13	0.230	555	7,500	88	10	3-Band Natural White
FL15EX-D-Z	6,700	15	T-8	25.5	436.0	G13	0.300	910	7,500	88	10	3-Band Daylight
FL15EX-N-Z	5,000	15	T-8	25.5	436.0	G13	0.300	970	7,500	88	10	3-Band Natural White
FL20T8EX-D/18*	6,500	18	T-8	25.5	588.7	G13	0.370	1,300	12,000	84	25	3-Band Daylight
FL20T8EX-N/18*	5,000	18	T-8	25.5	588.7	G13	0.370	1,350	12,000	84	25	3-Band Natural White
FL20T8EX-W/18*	4,000	18	T-8	25.5	588.7	G13	0.370	1,350	12,000	84	25	3-Band Cool White
FL20T8EX-WW/18*	3,000	18	T-8	25.5	588.7	G13	0.370	1,350	12,000	84	25	3-Band Warm White
FL40T8EX-D/36*	6,500	36	T-8	25.5	1,198.0	G13	0.430	3,250	20,000	84	25	3-Band Daylight
FL40T8EX-N/36*	5,000	36	T-8	25.5	1,198.0	G13	0.430	3,350	20,000	84	25	3-Band Natural White
FL40T8EX-W/36*	4,000	36	T-8	25.5	1,198.0	G13	0.430	3,350	20,000	84	25	3-Band Cool White
FL40T8EX-WW/36*	3,000	36	T-8	25.5	1,198.0	G13	0.430	3,350	20,000	84	25	3-Band Warm White
CIRCULAR TYPE												
FCL22EX-D/21*	6,500	21	T-9	29	210	G10q	0.380	1,220	9,000	84	30	3-Band Daylight
FCL30EX-D/28*	6,500	28	T-9	29	225	G10q	0.600	2,000	9,000	84	30	3-Band Daylight
FCL32EX-D/30*	6,500	30	T-9	29	300	G10q	0.425	2,360	9,000	84	20	3-Band Daylight

FHF LAMPS(T8 Rapid start energy-saving)

FHF lamps achieves maximized energy efficiency by operation with T8 rapid start ballast or electronic ballast. Both conventional and three band type are available with 2 sizes and 3 colors for any kinds of applications, including offices, conference rooms, stores and schools.



Product Order Code	Colour Temperature(K)	Watts (W)	Bulb Shape	Bulb Dia.(mm)	Bulb Length(mm)	Base	Rated Lamp Current(A)	Initial Lumens(lm)	Average Life(h)	Colour Rendering Index(Ra)	Std.Pkg. Qty	Colour Description
CONVENTIONAL TYPE												
FHF17D	6,500	17	T-8	25.5	588.7	G13	0.255	1,200	20,000	72	25	Daylight
FHF17CW	4,100	17	T-8	25.5	588.7	G13	0.255	1,330	20,000	61	25	Cool White
FHF17WW	3,000	17	T-8	25.5	588.7	G13	0.255	1,330	20,000	60	25	Warm White
FHF32D	6,500	32	T-8	25.5	1,198.0	G13	0.255	2,700	20,000	72	25	Daylight
FHF32CW	4,100	32	T-8	25.5	1,198.0	G13	0.255	2,850	20,000	61	25	Cool White
FHF32WW	3,000	32	T-8	25.5	1,198.0	G13	0.255	2,850	20,000	60	25	Warm White
THREE BAND TYPE												
FHF17EX-D	6,500	17	T-8	25.5	588.7	G13	0.255	1,320	20,000	84	25	3-Band Daylight
FHF17EX-CW	4,100	17	T-8	25.5	588.7	G13	0.255	1,400	20,000	84	25	3-Band Cool White
FHF17EX-WW	3,000	17	T-8	25.5	588.7	G13	0.255	1,400	20,000	84	25	3-Band Warm White
FHF32EX-D	6,500	32	T-8	25.5	1,198.0	G13	0.255	3,010	20,000	84	25	3-Band Daylight
FHF32EX-CW	4,100	32	T-8	25.5	1,198.0	G13	0.255	3,200	20,000	84	25	3-Band Cool White
FHF32EX-WW	3,000	32	T-8	25.5	1,198.0	G13	0.255	3,200	20,000	84	25	3-Band Warm White

Note : Measurements are made by high frequency operation.

PRE-HEAT START FLUORESCENT LAMPS

A " starter switch that operates only during the starting period is used with pre-heat start lamps to pre-heat the cathodes before starting.

The use of this starter permits more economical ballast designs.

Of all fluorescent lamps, this is the most economical type with long life, high lumen output and low initial cost.

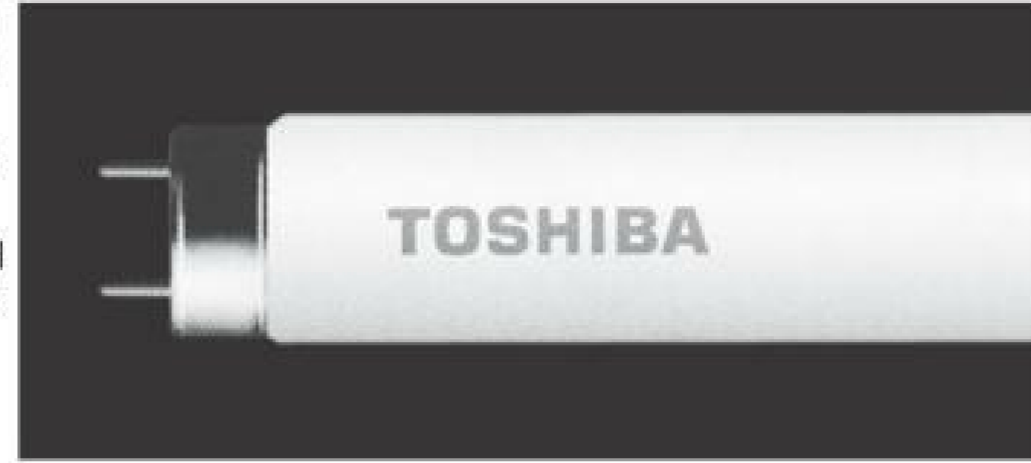

Product Order Code	Colour Temperature(K)	Watts (W)	Bulb Shape	Bulb Dia.(mm)	Bulb Length(mm)	Base	Rated Lamp Current(A)	Initial Lumens(lm)	Average Life(h)	Colour Rendering Index (Ra)	Std.Pkg.Q'ty		Colour Description
											Inner	Outer	
STRAIGHT TYPE													
FL4 D	6,500	4	T-5	15.5	134.5	G5	0.162	95	6,000	74	100	600	Daylight
FL4 W	4,200	4	T-5	15.5	134.5	G5	0.162	110	6,000	61	100	600	Cool White
FL4 WW	3,000	4	T-5	15.5	134.5	G5	0.162	110	6,000	60	100	600	Warm White
FL6 D	6,500	6	T-5	15.5	210.5	G5	0.147	220	7,500	74	100	600	Daylight
FL6 W	4,200	6	T-5	15.5	210.5	G5	0.147	245	7,500	61	100	600	Cool White
FL6 WW	3,000	6	T-5	15.5	210.5	G5	0.147	245	7,500	60	100	600	Warm White
FL8 D	6,500	8	T-5	15.5	287.0	G5	0.170	350	7,500	74	100	600	Daylight
FL8 W	4,200	8	T-5	15.5	287.0	G5	0.170	420	7,500	61	100	600	Cool White
FL8 WW	3,000	8	T-5	15.5	287.0	G5	0.170	420	7,500	60	100	600	Warm White
FL10 D	6,500	10	T-8	25.5	330.0	G13	0.230	440	7,500	74	25	200	Daylight
FL10 W	4,200	10	T-8	25.5	330.0	G13	0.230	500	7,500	61	25	200	Cool White
FL10 WW	3,000	10	T-8	25.5	330.0	G13	0.230	500	7,500	60	25	200	Warm White
FL15 D	6,500	15	T-8	25.5	436.0	G13	0.300	760	7,500	74	25	200	Daylight
FL15 W	4,200	15	T-8	25.5	436.0	G13	0.300	875	7,500	61	25	200	Cool White
FL15 WW	3,000	15	T-8	25.5	436.0	G13	0.300	875	7,500	60	25	200	Warm White
FL20T8D/18*	6,500	18	T-8	25.5	588.7	G13	0.370	1,090	12,000	74	-	25	Daylight
FL20T8W/18*	4,200	18	T-8	25.5	588.7	G13	0.370	1,200	12,000	61	-	25	Cool White
FL20T8WW/18*	3,000	18	T-8	25.5	588.7	G13	0.370	1,200	12,000	60	-	25	Warm White
FL30T8D	6,500	30	T-8	25.5	893.6	G13	0.365	2,000	12,000	74	-	25	Daylight
FL30T8W	4,200	30	T-8	25.5	893.6	G13	0.365	2,300	12,000	61	-	25	Cool White
FL30T8WW	3,000	30	T-8	25.5	893.6	G13	0.365	2,300	12,000	60	-	25	Warm White
FL40T8D/36*	6,500	36	T-8	25.5	1,198.0	G13	0.430	2,500	20,000	71	-	25	Daylight
FL40T8W/36*	4,200	36	T-8	25.5	1,198.0	G13	0.430	3,100	20,000	61	-	25	Cool White
FL40T8WW/36*	3,000	36	T-8	25.5	1,198.0	G13	0.430	3,100	20,000	60	-	25	Warm White
FL20T9D/19*	6,500	19	T-9	28.0	588.7	G13	0.350	1,070	12,000	74	-	25	Daylight
FL20T9W/19*	4,200	19	T-9	28.0	588.7	G13	0.350	1,230	12,000	61	-	25	Cool White
FL40T9D/38*	6,500	38	T-9	28.0	1,198.0	G13	0.410	2,700	20,000	74	-	25	Daylight
FL40T9W/38*	4,200	38	T-9	28.0	1,198.0	G13	0.410	3,100	20,000	61	-	25	Cool White
CIRCULAR TYPE													
FCL 22D/21*	6,500	21	T-9	29	210	G10q	0.380	1,080	9,000	74	-	30	Daylight
FCL 22W/21*	4,200	21	T-9	29	210	G10q	0.380	1,250	9,000	61	-	30	Cool White
FCL 30D/28*	6,500	28	T-9	29	230	G10q	0.620	1,550	9,000	74	-	30	Daylight
FCL 30W/28*	4,200	28	T-9	29	230	G10q	0.620	1,770	9,000	61	-	30	Cool White
FCL 32D/30*	6,500	30	T-9	29	300	G10q	0.435	1,890	9,000	74	-	20	Daylight
FCL 32W/30*	4,200	30	T-9	29	300	G10q	0.435	2,150	9,000	61	-	20	Cool White
FCL 40D/38*	6,500	38	T-9	29	406	G10q	0.420	2,000	9,000	74	-	10	Daylight
FCL 40W/38*	4,200	38	T-9	29	406	G10q	0.420	2,290	9,000	61	-	10	Cool White

IEC CLASSIFICATION ACCORDING TO THE DEGREE OF DUST AND MOISTURE PROTECTION (IP) INTERNATIONAL PROTECTION RATING



Dust protection			Moisture protection		
Symbol	First numeral	Degree of protection	Degree of protection	Second numeral	Symbol
	0	Non-protected	Non-protected	0	
	1	Protected against solid objects greater than 50 mm	Protected against dripping water	1	
	2	Protected against solid objects greater than 12 mm	Protected against dripping water when tilted up to 15°	2	
	3	Protected against solid objects greater than 2.5 mm	Protected against spraying water 60°	3	
	4	Protected against solid objects greater than 1.0 mm	Protected against splashing water	4	
	5	Dust-protected	Protected against water jets	5	
	6	Dust-tight	Protected against heavy seas	6	
			Protected against effects of immersion up to 1m	7	
			Protected against submersion immersion beyond 1m	8	

ADEQUATE LIGHT LEVELS FOR WORKING AREAS



LOCATIONS	LUX (lx)															
	10,000	5,000	3,000	2,000	1,500	1,000	750	500	300	200	150	100	75	50	30	20
FACTORY			ELECTRONIC PARTS ASSEMBLY LINE. - DRAFTING.	TYPESSETTING AT PRINTING SHOP. - INSPECTION WORK.	VISUAL WORK AT PRODUCTION LINE.	- PACKING WORK.					EXIT. ENTRANCE. PASSAGE.	INDOOR EMERGENCY STAIRS. WAREHOUSE. - LOADING OR UNLOADING WORK.				
OFFICE			- TYPING. - DRAFTING.	CLERICAL WORK.	CONFERENCE ROOM. DINING ROOM. RECEPTION ROOM.						CORRIDOR. STAIRS.	ENTRANCE. WAREHOUSE.	INDOOR EMERGENCY STAIRS.			
HOUSE			- SEWING.	- READING. - STUDY.	- MAKEUP.	- DINING TABLE.	- RECREATIONAL ACTIVITIES.	- WASHING.								
STORE			- FOREFRONT OF SHOW WINDOW.	- SHOW WINDOW. - PACKING TABLE.	ELEVATOR.	- DISPLAY STAND.	RECEPTION ROOM.	CORRIDOR STAIRS.	INDOORS.							
HOSPITAL	EYE INSPECTION.			OPERATING ROOM. EMERGENCY TREATMENT.	MEDICAL EXAMINATION ROOM. DINING ROOM.		WAITING ROOM.	SICK ROOM. WAREHOUSE.	STAIRS.				EMERGENCY STAIRS.			
SCHOOL			- DRAFTING ROOM. - LABORATORY. - LIBRARY.		GLASS ROOM.		INDOOR GYMNASIUM. AUDITORIUM. WASH ROOM.						EMERGENCY STAIRS.			
RESTAURANT			- SHOW WINDOW.		COOKING ROOM. DINING TABLE.		ENTRANCE. WASH ROOM.	CORRIDOR. STAIRS.								
BABER, BEAUTY PARLOR			- HAIR DYEING. - MAKEUP. - HAIR DRESSING.		- SHAVING. - HAIR WASHING. - DRESSING.											

* REQUIRED LIGHT LEVEL MAY BE OBTAINED BY LOCAL ILLUMINATION FOR THOSE MARKED -. IN THIS CASE DESIRED LIGHT VALUE OF TOTAL ILLUMINATION IS ONE TENTH OF LOCAL ILLUMINATION LEVEL.

CALCULATION METHOD OF ILLUMINANCE BY LUMEN



STEP 1 DETERMINE ROOM INDEX (K)

$$K = \frac{LW}{(L + W) H}$$

L = ROOM LENGTH IN metre (exp: 22 metre)
 W = ROOM WIDTH IN metre (exp: 11 metre)
 H = HEIGHT FR WORK PLANE TO LAMP SOURCE- 2.4 metre

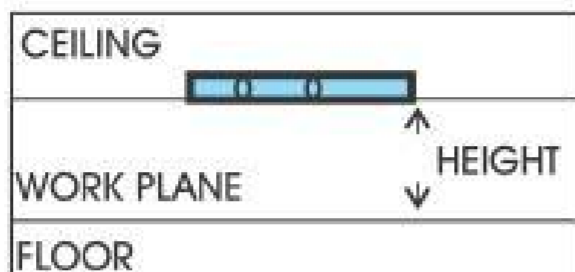

OFFICE - ROOM AREA IN metre

A 22 x 11

$$K = \frac{22 \times 11}{(22 + 11) \times 2.4} = \frac{242}{79.2} = 3$$

STEP 2 DETERMINE CEILING, WALL AND FLOOR REFLECTION FACTOR

A) CEILING REFLECTION FACTOR (c)	STANDARD WHITE PAINT = 70% ROUGH WHITE PAINT = 50% ROUGH LIGHT PAINT = 30%	0.7
B) WALL REFLECTION FACTOR (w)	WHITE PAINT = 50% ROUGH LIGHT PAINT = 30% DARK PAINT = 10%	0.5
C) FLOOR REFLECTION FACTOR (f)	DARK CONCRETE = 20% CARPET AVERAGE = 10%	0.2

STEP 3 DETERMINE UTILISATION FACTOR (UF) FROM THE UF TABLE IN CATALOGUE.

K = 3 JUNCTION WITH c = 0.7; w = 0.5; f = 0.2 == READ: 66% UF 0.66

STEP 4 CALCULATE NUMBER OF LUMINAIRES / FITTING REQUIRED

$$N = \frac{E \text{ (LUX)} \times A \text{ (m}^2\text{)}}{\phi \text{ (LUMEN)} \times MF \times UF}$$

E = ILLUMINANCE, LUX (lx) E 400
 exp : OFFICE : 400 LUX (lx); WAREHOUSE: 100 LUX (lx)
 (RECOMMENDED BY LUMINAIRES/FITTINGS MANUFACTURER)
 A = AREA IN m²(ROOM LENGTH x WIDTH : AS SHOWN IN STEP 1)
 φ = LUMINOUS FLUX FOR LUMINAIRES / FITTINGS, LUMEN (lm)
 exp A : A) YLI RECESSED MIRROR LOUVER FITTING: YML 2424/R,
 B) TOSHIBA FLU. TUBE: FL40T8EX-D/36, OFFER: 3,250 lm.
 1 FITTING = 2 TUBE x 3,250 = 6,500 lm. φ 6,500
 MF = MAINTENANCE FACTOR (NORMALLY 70% - 80%) MF 0.8
 UF = UTILISATION FACTOR (FROM UF TABLE / AS SHOWN IN STEP 3)

$$N = \frac{400 \times (22 \times 11)}{6,500 \times 0.8 \times 0.66} = \frac{96,800}{3,432} = 28.2 = \text{LUMINAIRES/ FITTINGS 29 UNITS}$$

exp B: A) YLI RECESSED MIRROR LOUVER FITTING: YML 2424/R,
 B) TOSHIBA FLU. TUBE : FL40T8D/36, OFFER: 2,500 lm

$$N = \frac{400 \times (22 \times 11)}{5,000 \times 0.8 \times 0.66} = \frac{96,800}{2,640} = 36.6 = \text{LUMINAIRES/ FITTINGS 37 UNITS}$$

PHOTOMETRIC DATA

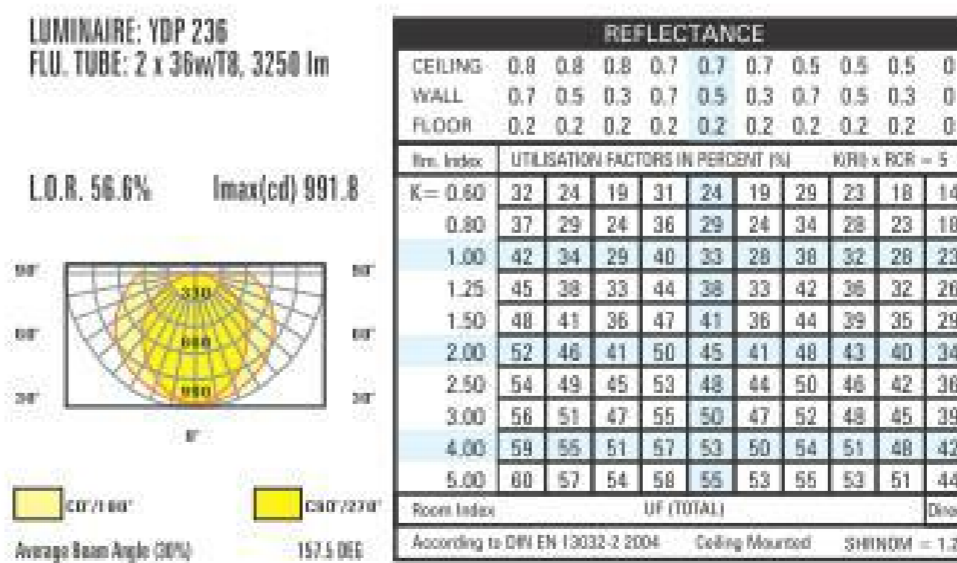
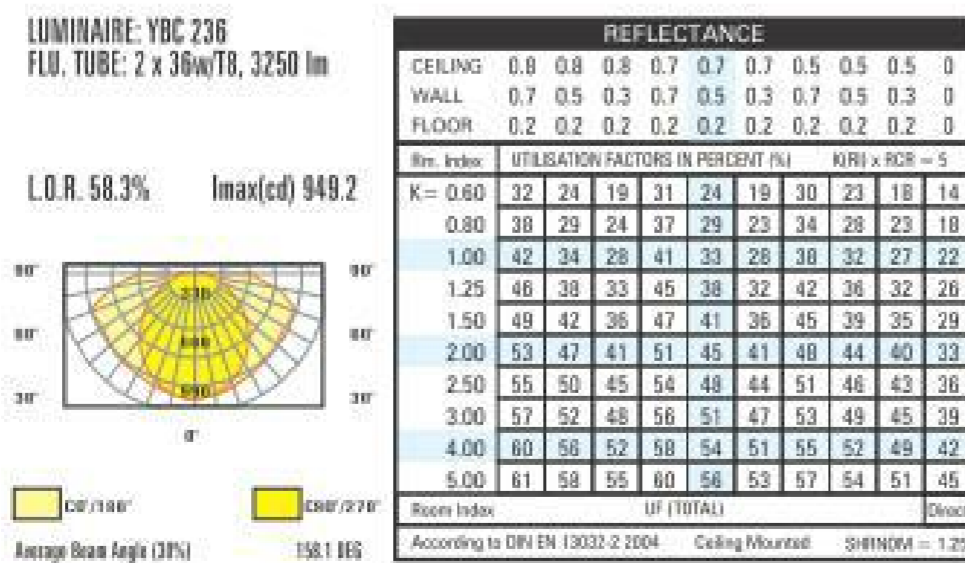
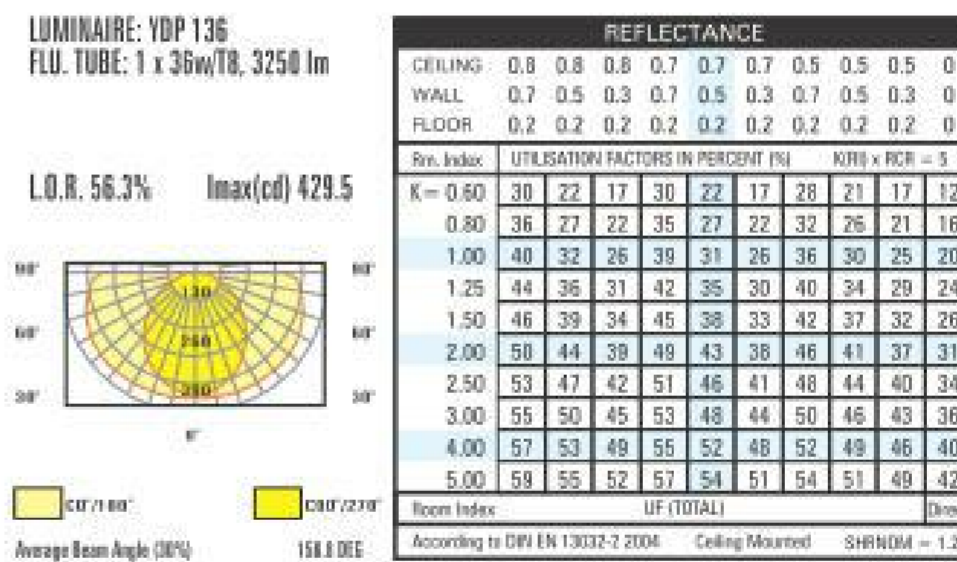
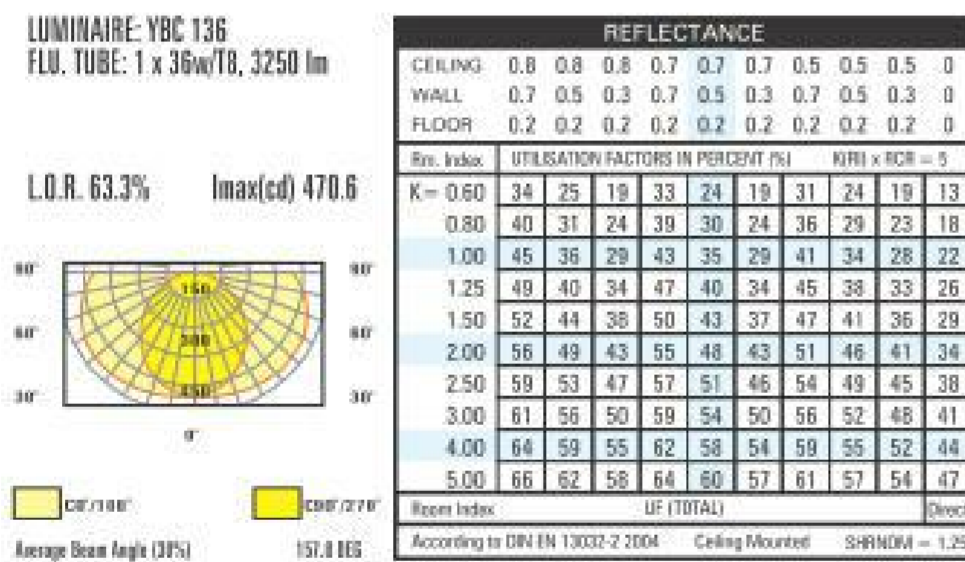
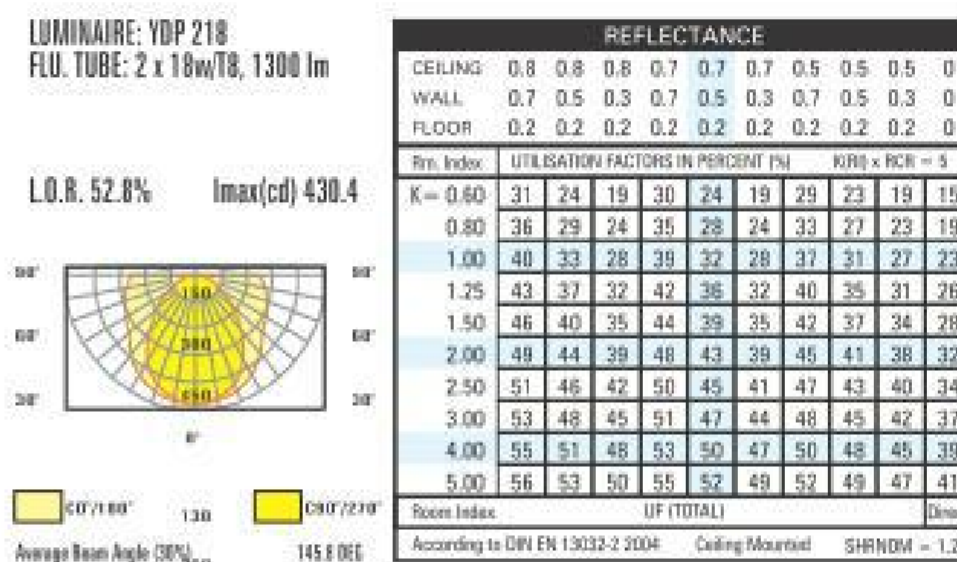
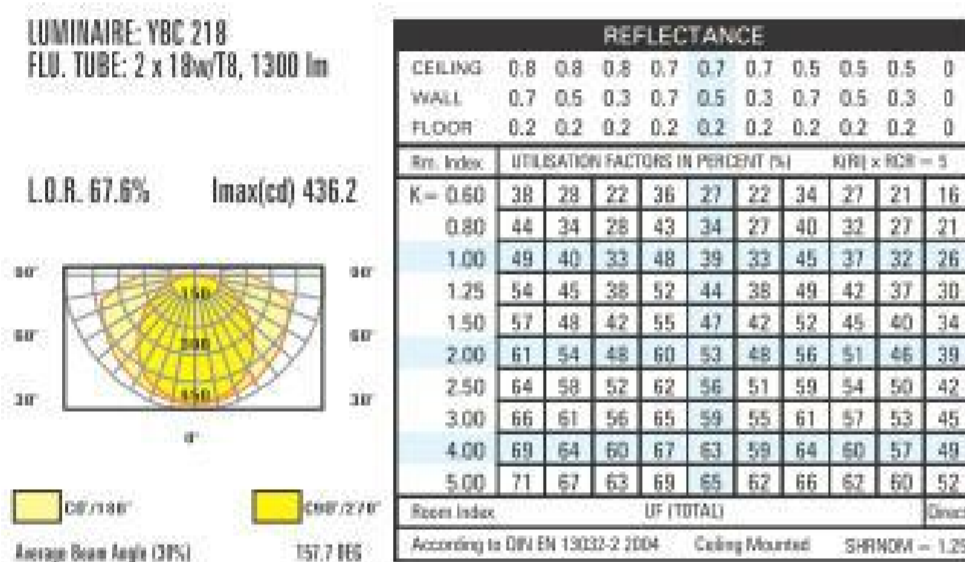
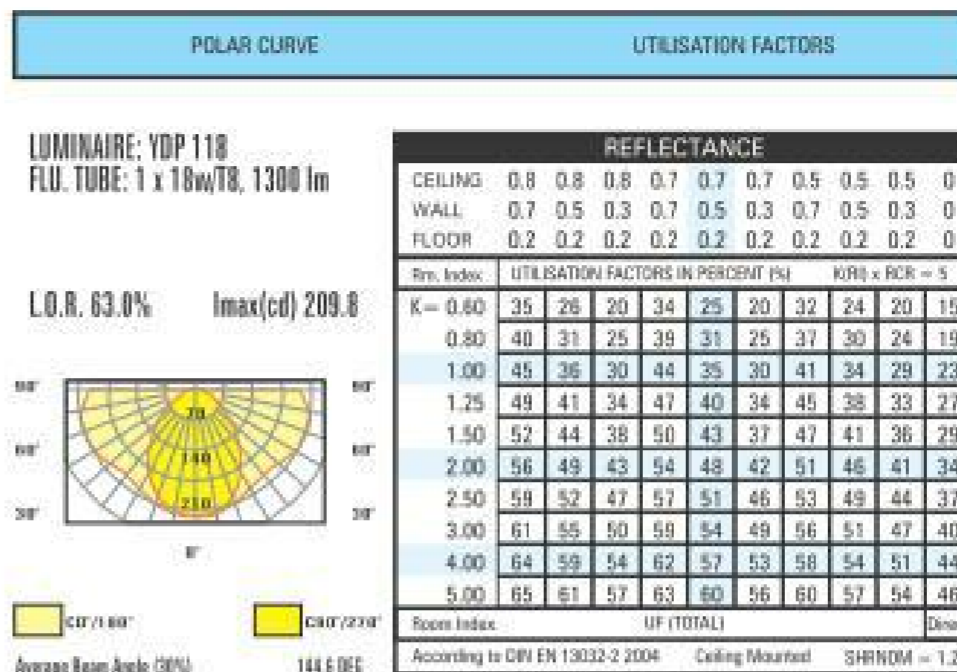
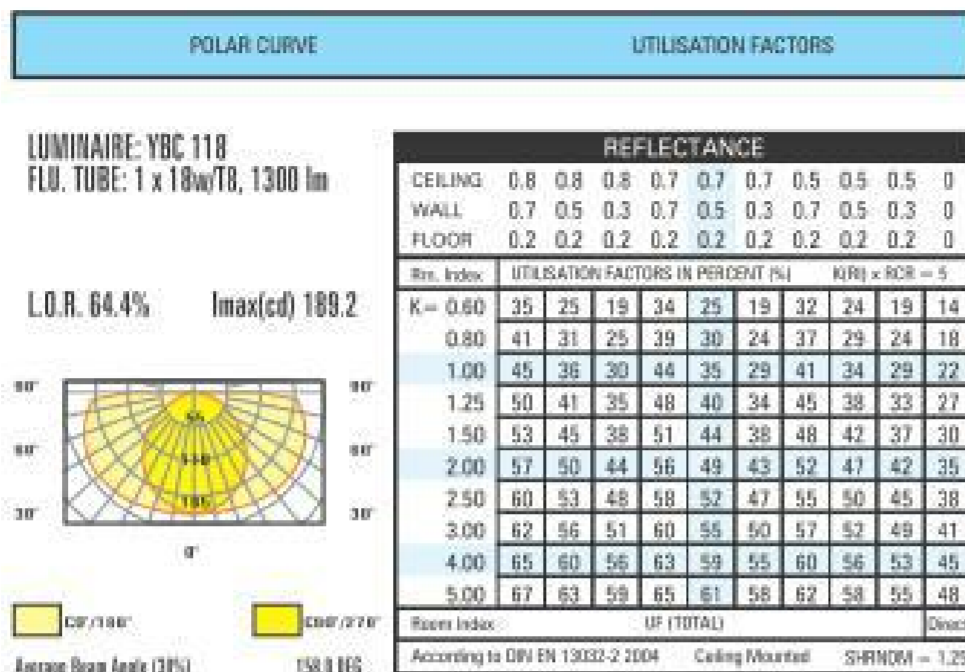

PHOTOMETRIC DATA



POLAR CURVE UTILISATION FACTORS

LUMINAIRE: YWG 118
FLU. TUBE: 1 x 18w/T8, 1300 lm

L.O.R. 69.9% I_{max}(cd) 217.0

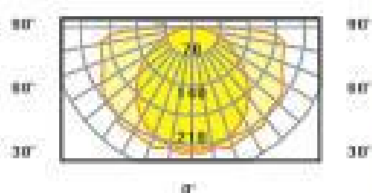

Average Beam Angle (30%) 158.2 DEG

REFLECTANCE	
CEILING	0.8 0.8 0.8 0.7 0.7 0.7 0.5 0.5 0.5 0
WALL	0.7 0.5 0.3 0.7 0.5 0.3 0.7 0.5 0.3 0
FLOOR	0.2 0.2 0.2 0.2 0.2 0.2 0.2 0.2 0.2 0
Rm. Index	UTILISATION FACTORS IN PERCENT (%) K/R0 x RCR = 5
K= 0.60	38 28 22 37 28 22 35 27 22 16
0.80	45 35 28 44 34 28 41 33 27 21
1.00	50 41 34 49 40 33 46 38 33 26
1.25	55 46 39 53 45 38 50 43 37 30
1.50	58 50 43 56 48 42 53 46 41 34
2.00	63 55 49 61 54 48 58 52 47 39
2.50	66 59 53 64 58 52 60 55 51 43
3.00	68 62 57 66 61 56 63 58 54 46
4.00	71 66 62 69 65 60 66 62 58 50
5.00	73 69 65 71 67 63 67 64 61 53
Room Index	UF (TOTAL) Direct
According to DIN EN 13032-2 2004 Ceiling Mounted SHRNDM = 1.25	

POLAR CURVE UTILISATION FACTORS

LUMINAIRE: YMT 118
FLU. TUBE: 1 x 18w/T8, 1300 lm

L.O.R. 63.3% I_{max}(cd) 196.2

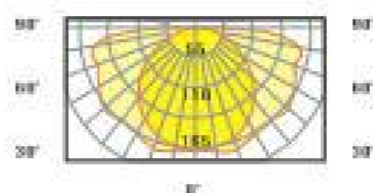

Average Beam Angle (30%) 66.4 DEG

REFLECTANCE	
CEILING	0.8 0.8 0.8 0.7 0.7 0.7 0.5 0.5 0.5 0
WALL	0.7 0.5 0.3 0.7 0.5 0.3 0.7 0.5 0.3 0
FLOOR	0.2 0.2 0.2 0.2 0.2 0.2 0.2 0.2 0.2 0
Rm. Index	UTILISATION FACTORS IN PERCENT (%) K/R0 x RCR = 5
K= 0.60	35 25 20 34 25 20 32 24 19 14
0.80	41 31 25 39 31 25 37 30 24 19
1.00	45 36 30 44 36 30 41 34 29 23
1.25	50 41 35 48 40 34 45 39 33 27
1.50	53 45 38 51 44 38 48 42 37 30
2.00	57 50 44 55 49 43 52 46 42 35
2.50	59 53 48 58 52 47 54 49 45 38
3.00	62 56 51 60 55 50 56 52 48 41
4.00	64 60 55 63 58 54 59 55 52 45
5.00	66 62 56 64 61 57 61 58 55 48
Room Index	UF (TOTAL) Direct
According to DIN EN 13032-2 2004 Ceiling Mounted SHRNDM = 1.25	

LUMINAIRE: YWG 218
FLU. TUBE: 2 x 18w/T8, 1300 lm

L.O.R. 65.0% I_{max}(cd) 435.6

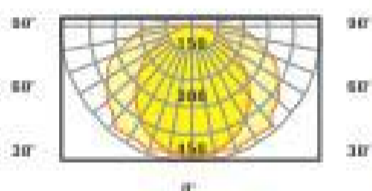

Average Beam Angle (30%) 155.5 DEG

REFLECTANCE	
CEILING	0.8 0.8 0.8 0.7 0.7 0.7 0.5 0.5 0.5 0
WALL	0.7 0.5 0.3 0.7 0.5 0.3 0.7 0.5 0.3 0
FLOOR	0.2 0.2 0.2 0.2 0.2 0.2 0.2 0.2 0.2 0
Rm. Index	UTILISATION FACTORS IN PERCENT (%) K/R0 x RCR = 5
K= 0.60	37 27 22 36 27 22 34 26 21 16
0.80	43 34 28 42 33 27 39 32 27 21
1.00	48 39 33 47 38 33 44 37 32 26
1.25	52 44 38 51 43 38 48 42 37 30
1.50	55 48 42 54 47 41 51 45 40 34
2.00	60 53 48 58 52 47 55 50 46 39
2.50	62 56 51 61 55 51 57 53 49 42
3.00	65 59 55 63 58 54 59 55 52 45
4.00	67 63 59 66 62 58 62 59 56 49
5.00	69 65 62 67 64 61 64 61 58 51
Room Index	UF (TOTAL) Direct
According to DIN EN 13032-2 2004 Ceiling Mounted SHRNDM = 1.25	

LUMINAIRE: YMT 218
FLU. TUBE: 2 x 18w/T8, 1300 lm

L.O.R. 67.1% I_{max}(cd) 464.0

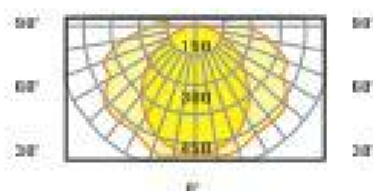

Average Beam Angle (30%) 153.4 DEG

REFLECTANCE	
CEILING	0.8 0.8 0.8 0.7 0.7 0.7 0.5 0.5 0.5 0
WALL	0.7 0.5 0.3 0.7 0.5 0.3 0.7 0.5 0.3 0
FLOOR	0.2 0.2 0.2 0.2 0.2 0.2 0.2 0.2 0.2 0
Rm. Index	UTILISATION FACTORS IN PERCENT (%) K/R0 x RCR = 5
K= 0.60	38 28 22 37 28 22 35 27 22 17
0.80	44 35 28 43 34 28 40 33 28 22
1.00	49 40 34 48 40 34 45 38 33 27
1.25	54 45 39 52 45 39 49 43 38 31
1.50	57 49 43 55 48 43 52 46 41 35
2.00	62 55 49 60 54 48 57 51 47 40
2.50	64 58 53 63 57 52 59 54 50 43
3.00	67 61 56 65 60 55 61 57 54 46
4.00	70 65 61 68 63 60 64 61 58 50
5.00	71 67 64 69 66 63 66 63 60 53
Room Index	UF (TOTAL) Direct
According to DIN EN 13032-2 2004 Ceiling Mounted SHRNDM = 1.25	

LUMINAIRE: YWG 136
FLU. TUBE: 1 x 36w/T8, 3250 lm

L.O.R. 59.2% I_{max}(cd) 455.4

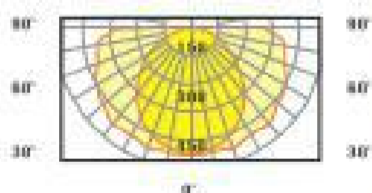

Average Beam Angle (30%) 158.7 DEG

REFLECTANCE	
CEILING	0.8 0.8 0.8 0.7 0.7 0.7 0.5 0.5 0.5 0
WALL	0.7 0.5 0.3 0.7 0.5 0.3 0.7 0.5 0.3 0
FLOOR	0.2 0.2 0.2 0.2 0.2 0.2 0.2 0.2 0.2 0
Rm. Index	UTILISATION FACTORS IN PERCENT (%) K/R0 x RCR = 5
K= 0.60	32 24 19 32 24 18 30 23 18 13
0.80	38 29 24 37 29 23 35 28 23 18
1.00	43 34 29 41 34 28 39 32 27 22
1.25	46 39 33 45 38 32 42 36 32 26
1.50	49 42 36 48 41 36 45 39 35 29
2.00	53 47 42 52 46 41 49 44 40 33
2.50	56 50 45 54 49 44 51 47 43 36
3.00	58 53 48 56 51 47 53 49 46 39
4.00	60 56 52 59 55 51 55 52 49 42
5.00	62 58 55 60 57 54 57 54 52 45
Room Index	UF (TOTAL) Direct
According to DIN EN 13032-2 2004 Ceiling Mounted SHRNDM = 1.25	

LUMINAIRE: YMT 136
FLU. TUBE: 1 x 36w/T8, 3250 lm

L.O.R. 59.8% I_{max}(cd) 463.4

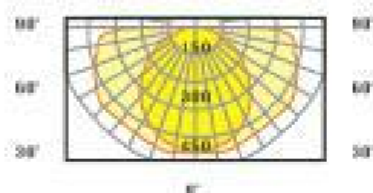

Average Beam Angle (30%) 155.1 DEG

REFLECTANCE	
CEILING	0.8 0.8 0.8 0.7 0.7 0.7 0.5 0.5 0.5 0
WALL	0.7 0.5 0.3 0.7 0.5 0.3 0.7 0.5 0.3 0
FLOOR	0.2 0.2 0.2 0.2 0.2 0.2 0.2 0.2 0.2 0
Rm. Index	UTILISATION FACTORS IN PERCENT (%) K/R0 x RCR = 5
K= 0.60	33 24 19 32 24 19 30 23 18 14
0.80	38 30 24 37 29 24 35 28 23 18
1.00	43 34 29 42 34 28 39 32 28 22
1.25	47 39 33 45 38 33 43 37 32 26
1.50	50 42 37 48 41 36 45 40 35 29
2.00	54 47 42 52 46 41 49 44 40 33
2.50	56 50 45 55 49 45 51 47 43 36
3.00	58 53 48 57 52 48 53 49 46 39
4.00	61 56 52 59 55 51 56 53 50 43
5.00	63 59 55 61 57 54 58 55 52 45
Room Index	UF (TOTAL) Direct
According to DIN EN 13032-2 2004 Ceiling Mounted SHRNDM = 1.25	

LUMINAIRE: YWG 236
FLU. TUBE: 2 x 36w/T8, 3250 lm

L.O.R. 60.8% I_{max}(cd) 1034

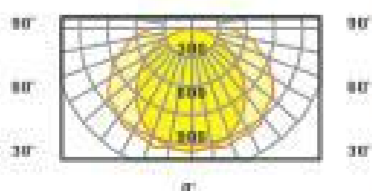

Average Beam Angle (30%) 158.7 DEG

REFLECTANCE	
CEILING	0.8 0.8 0.8 0.7 0.7 0.7 0.5 0.5 0.5 0
WALL	0.7 0.5 0.3 0.7 0.5 0.3 0.7 0.5 0.3 0
FLOOR	0.2 0.2 0.2 0.2 0.2 0.2 0.2 0.2 0.2 0
Rm. Index	UTILISATION FACTORS IN PERCENT (%) K/R0 x RCR = 5
K= 0.60	34 26 20 33 25 20 32 24 20 15
0.80	40 31 26 39 31 26 37 30 25 20
1.00	45 37 31 44 36 31 41 35 30 24
1.25	49 41 36 48 40 35 45 39 34 29
1.50	52 45 39 50 44 39 48 42 38 32
2.00	58 50 45 54 49 44 51 47 43 36
2.50	59 53 48 57 52 47 54 49 46 39
3.00	61 56 51 59 54 50 56 52 49 42
4.00	63 59 55 61 58 54 58 55 52 46
5.00	65 61 58 63 60 57 60 57 55 48
Room Index	UF (TOTAL) Direct
According to DIN EN 13032-2 2004 Ceiling Mounted SHRNDM = 1.25	

LUMINAIRE: YMT 236
FLU. TUBE: 2 x 36w/T8, 3250 lm

L.O.R. 58.2% I_{max}(cd) 1020

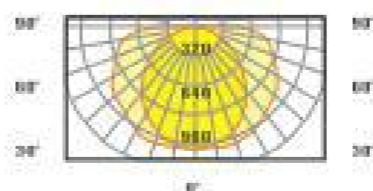

Average Beam Angle (30%) 155.8 DEG

REFLECTANCE	
CEILING	0.8 0.8 0.8 0.7 0.7 0.7 0.5 0.5 0.5 0
WALL	0.7 0.5 0.3 0.7 0.5 0.3 0.7 0.5 0.3 0
FLOOR	0.2 0.2 0.2 0.2 0.2 0.2 0.2 0.2 0.2 0
Rm. Index	UTILISATION FACTORS IN PERCENT (%) K/R0 x RCR = 5
K= 0.60	34 25 20 33 25 20 31 24 20 15
0.80	39 31 25 38 30 25 36 29 25 19
1.00	44 36 30 43 35 30 40 34 29 24
1.25	48 40 35 46 40 34 44 38 34 28
1.50	51 44 38 49 43 38 46 41 37 31
2.00	55 48 44 53 47 43 50 45 42 35
2.50	57 51 47 55 50 46 52 48 45 38
3.00	59 54 50 57 53 49 54 50 47 41
4.00	61 57 54 60 56 53 56 53 51 44
5.00	63 59 56 61 58 55 58 55 53 46
Room Index	UF (TOTAL) Direct
According to DIN EN 13032-2 2004 Ceiling Mounted SHRNDM = 1.25	

PHOTOMETRIC DATA

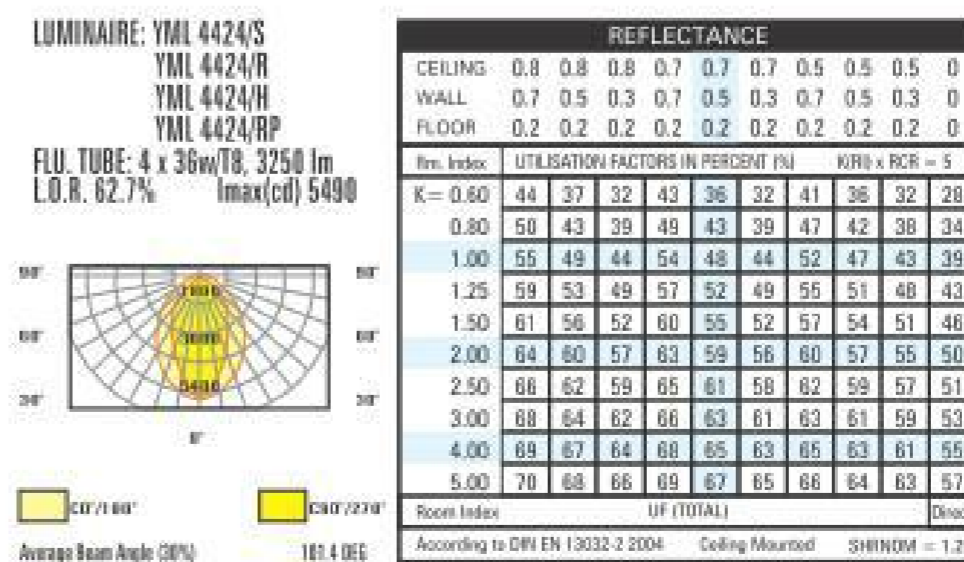
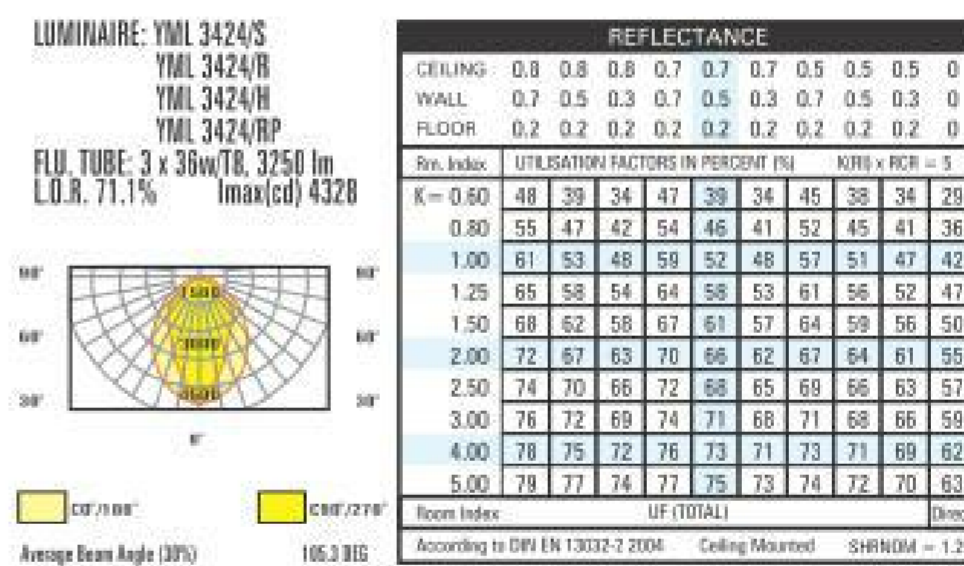
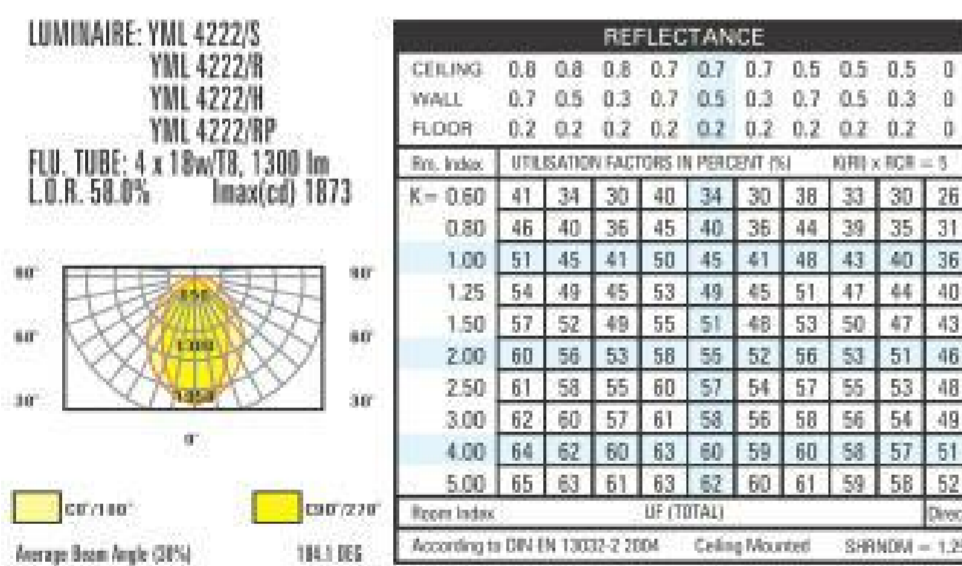
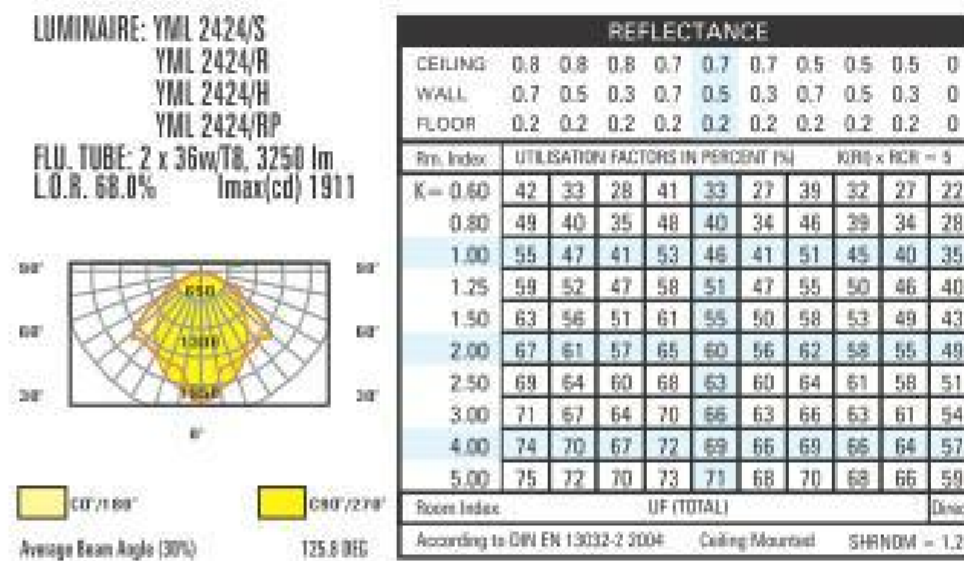
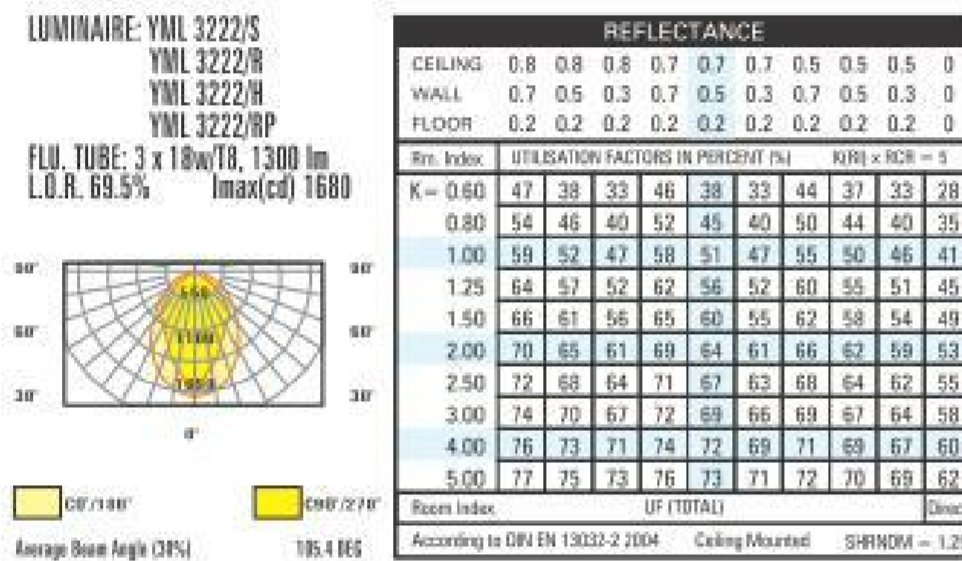
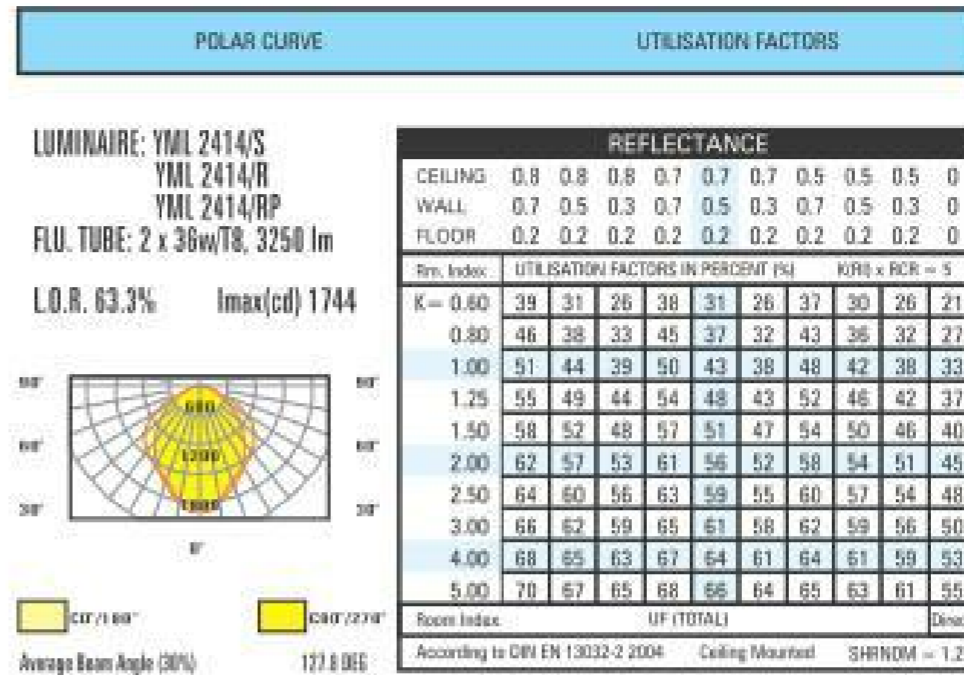
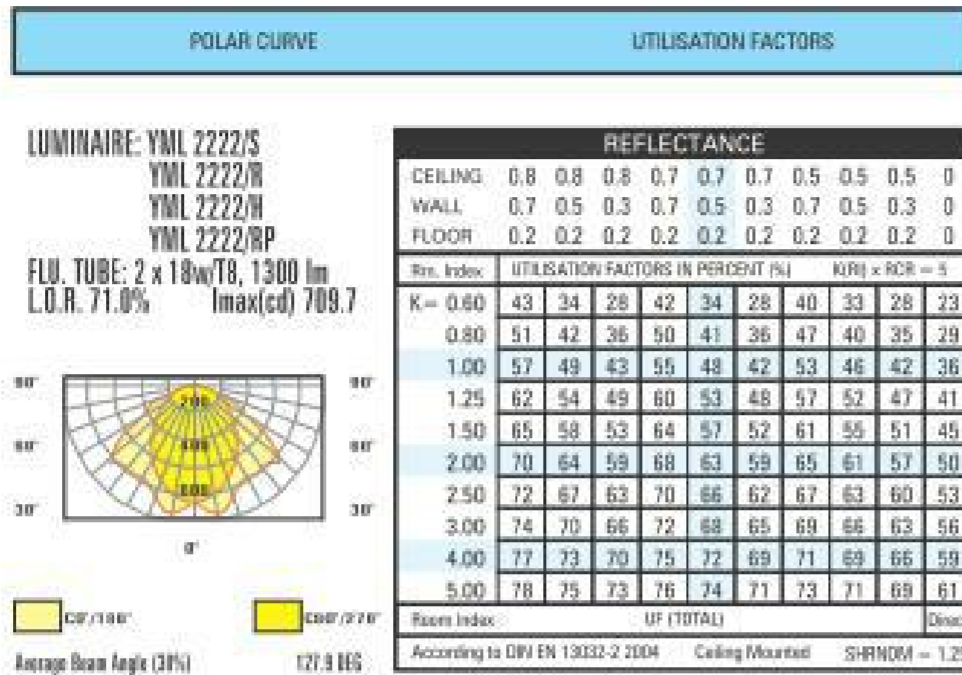

PHOTOMETRIC DATA



POLAR CURVE UTILISATION FACTORS

LUMINAIRE: YID 218/A
FLU. TUBE: 2 x 18w/T8, 1300 lm

L.O.R. 41.6% I_{max}(cd) 331.9

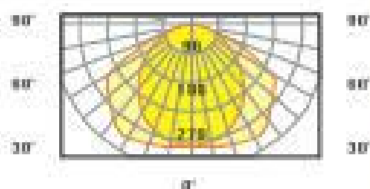

Average Beam Angle (30%) 138.1 DEG

REFLECTANCE										
	0.8	0.8	0.8	0.7	0.7	0.7	0.5	0.5	0.5	0
CEILING	0.8	0.8	0.8	0.7	0.7	0.7	0.5	0.5	0.5	0
WALL	0.7	0.5	0.3	0.7	0.5	0.3	0.7	0.5	0.3	0
FLOOR	0.2	0.2	0.2	0.2	0.2	0.2	0.2	0.2	0.2	0
Room Index	UTILISATION FACTORS IN PERCENT (%) K(R) x RCR = 5									
K= 0.60	24	19	15	24	19	15	23	18	15	12
0.80	29	23	19	28	23	19	27	22	19	16
1.00	32	27	23	31	27	23	30	26	23	19
1.25	35	30	27	34	30	27	33	29	26	22
1.50	37	33	30	36	32	29	34	31	28	25
2.00	40	36	33	39	36	33	37	34	32	28
2.50	42	38	35	40	37	35	39	36	34	30
3.00	43	40	38	42	39	37	40	38	36	32
4.00	44	42	40	43	41	39	41	40	38	34
5.00	45	43	42	44	43	41	42	41	39	35
Room Index	UF (TOTAL) Direct									

According to DIN EN 13032-2:2004 Ceiling Mounted SHRNDM = 1.25

POLAR CURVE UTILISATION FACTORS

LUMINAIRE: YID 218/V
FLU. TUBE: 2 x 18w/T8, 1300 lm

L.O.R. 39.1% I_{max}(cd) 305.7

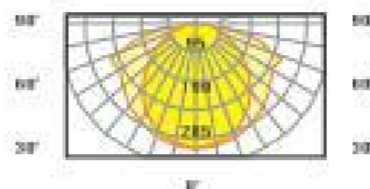

Average Beam Angle (30%) 145.8 DEG

REFLECTANCE										
	0.8	0.8	0.8	0.7	0.7	0.7	0.5	0.5	0.5	0
CEILING	0.8	0.8	0.8	0.7	0.7	0.7	0.5	0.5	0.5	0
WALL	0.7	0.5	0.3	0.7	0.5	0.3	0.7	0.5	0.3	0
FLOOR	0.2	0.2	0.2	0.2	0.2	0.2	0.2	0.2	0.2	0
Room Index	UTILISATION FACTORS IN PERCENT (%) K(R) x RCR = 5									
K= 0.60	23	18	14	22	17	14	21	17	14	11
0.80	27	21	18	26	21	18	25	20	17	14
1.00	30	25	21	29	24	21	28	24	21	17
1.25	32	28	25	32	27	24	30	26	24	20
1.50	34	30	27	33	30	26	32	28	26	22
2.00	37	33	30	36	33	30	34	31	29	25
2.50	39	35	33	37	35	32	36	33	31	27
3.00	40	37	35	39	36	34	37	35	33	29
4.00	41	39	37	40	38	36	38	37	35	31
5.00	42	40	39	41	40	38	39	38	37	32
Room Index	UF (TOTAL) Direct									

According to DIN EN 13032-2:2004 Ceiling Mounted SHRNDM = 1.25

LUMINAIRE: YID 318/A
FLU. TUBE: 3 x 18w/T8, 1300 lm

L.O.R. 40.2% I_{max}(cd) 466.7

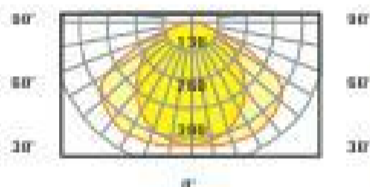

Average Beam Angle (30%) 138.3 DEG

REFLECTANCE										
	0.8	0.8	0.8	0.7	0.7	0.7	0.5	0.5	0.5	0
CEILING	0.8	0.8	0.8	0.7	0.7	0.7	0.5	0.5	0.5	0
WALL	0.7	0.5	0.3	0.7	0.5	0.3	0.7	0.5	0.3	0
FLOOR	0.2	0.2	0.2	0.2	0.2	0.2	0.2	0.2	0.2	0
Room Index	UTILISATION FACTORS IN PERCENT (%) K(R) x RCR = 5									
K= 0.60	23	18	15	23	18	14	22	17	14	11
0.80	28	22	19	27	22	18	25	21	18	15
1.00	31	26	22	30	25	22	29	25	22	18
1.25	34	29	26	33	29	26	31	28	25	21
1.50	36	32	28	35	31	28	33	30	27	24
2.00	39	35	32	38	34	32	36	33	31	27
2.50	40	37	34	39	35	34	37	35	33	29
3.00	41	39	36	40	38	36	38	36	34	30
4.00	43	41	39	42	40	38	40	38	37	33
5.00	44	42	40	43	41	40	41	39	38	34
Room Index	UF (TOTAL) Direct									

According to DIN EN 13032-2:2004 Ceiling Mounted SHRNDM = 1.25

LUMINAIRE: YID 236/V
FLU. TUBE: 2 x 36w/T8, 3250 lm

L.O.R. 35.6% I_{max}(cd) 698.6

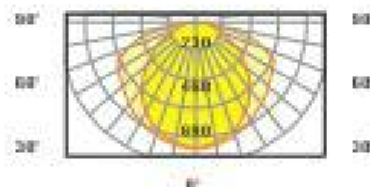

Average Beam Angle (30%) 145.8 DEG

REFLECTANCE										
	0.8	0.8	0.8	0.7	0.7	0.7	0.5	0.5	0.5	0
CEILING	0.8	0.8	0.8	0.7	0.7	0.7	0.5	0.5	0.5	0
WALL	0.7	0.5	0.3	0.7	0.5	0.3	0.7	0.5	0.3	0
FLOOR	0.2	0.2	0.2	0.2	0.2	0.2	0.2	0.2	0.2	0
Room Index	UTILISATION FACTORS IN PERCENT (%) K(R) x RCR = 5									
K= 0.60	21	16	13	20	16	13	19	15	13	10
0.80	24	20	16	24	19	16	22	19	16	13
1.00	27	23	20	26	22	19	25	22	19	16
1.25	30	25	22	29	25	22	27	24	22	18
1.50	31	27	25	31	27	24	29	26	24	20
2.00	34	30	28	33	30	27	31	29	27	23
2.50	35	32	30	34	32	29	32	30	28	25
3.00	36	34	32	35	33	31	34	32	30	26
4.00	38	36	34	37	35	33	35	33	32	28
5.00	39	37	35	38	36	35	36	35	33	30
Room Index	UF (TOTAL) Direct									

According to DIN EN 13032-2:2004 Ceiling Mounted SHRNDM = 1.25

LUMINAIRE: YID 236/A
FLU. TUBE: 2 x 36w/T8, 3250 lm

L.O.R. 36.4% I_{max}(cd) 713.4

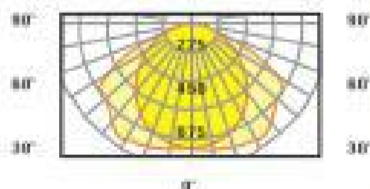

Average Beam Angle (30%) 137.8 DEG

REFLECTANCE										
	0.8	0.8	0.8	0.7	0.7	0.7	0.5	0.5	0.5	0
CEILING	0.8	0.8	0.8	0.7	0.7	0.7	0.5	0.5	0.5	0
WALL	0.7	0.5	0.3	0.7	0.5	0.3	0.7	0.5	0.3	0
FLOOR	0.2	0.2	0.2	0.2	0.2	0.2	0.2	0.2	0.2	0
Room Index	UTILISATION FACTORS IN PERCENT (%) K(R) x RCR = 5									
K= 0.60	21	16	13	21	16	13	20	16	13	10
0.80	25	20	17	24	20	17	23	19	16	13
1.00	28	24	20	27	23	20	26	22	20	17
1.25	31	26	23	30	26	23	28	25	23	19
1.50	32	29	26	32	28	25	30	27	25	21
2.00	35	32	29	34	31	29	32	30	28	24
2.50	36	33	31	35	33	31	34	31	30	26
3.00	37	35	33	37	34	32	35	33	31	28
4.00	39	37	35	38	36	34	36	35	33	30
5.00	40	38	36	39	37	36	37	36	34	31
Room Index	UF (TOTAL) Direct									

According to DIN EN 13032-2:2004 Ceiling Mounted SHRNDM = 1.25

LUMINAIRE: YID 336/A
FLU. TUBE: 3 x 36w/T8, 3250 lm

L.O.R. 35.4% I_{max}(cd) 1007

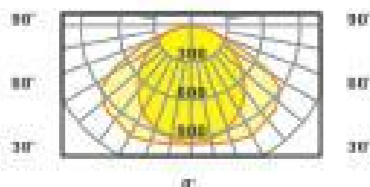

Average Beam Angle (30%) 138.2 DEG

REFLECTANCE										
	0.8	0.8	0.8	0.7	0.7	0.7	0.5	0.5	0.5	0
CEILING	0.8	0.8	0.8	0.7	0.7	0.7	0.5	0.5	0.5	0
WALL	0.7	0.5	0.3	0.7	0.5	0.3	0.7	0.5	0.3	0
FLOOR	0.2	0.2	0.2	0.2	0.2	0.2	0.2	0.2	0.2	0
Room Index	UTILISATION FACTORS IN PERCENT (%) K(R) x RCR = 5									
K= 0.60	20	16	13	20	15	12	19	15	12	10
0.80	24	19	16	23	19	16	22	18	16	13
1.00	27	23	20	26	22	19	25	22	19	16
1.25	30	26	23	29	25	22	27	24	22	19
1.50	31	28	25	31	27	24	29	26	24	20
2.00	34	31	28	33	30	28	31	29	27	23
2.50	35	32	30	34	32	30	33	30	29	25
3.00	36	34	32	35	33	31	34	32	30	27
4.00	38	36	34	37	35	33	35	34	32	29
5.00	39	37	35	38	36	35	36	35	33	30
Room Index	UF (TOTAL) Direct									

According to DIN EN 13032-2:2004 Ceiling Mounted SHRNDM = 1.25

CONTACT DETAILS



MALAYSIA

HEAD QUARTER AND MANUFACTURE BASE

YLI INDUSTRY SDN. BHD.

(504654-U)

PT 14504, Persiaran Batu Gajah Perdana 6, Taman Batu Gajah Perdana, 31550 Pusing, Perak, Malaysia
Tel: +60-5-366 5227 (Hunting Line), 366 7227, 366 8227, 366 9227 Fax: +60-5-365 3227, 365 1227
Email: yli@streamyx.com Website: www.yli-ind.com.my

SINGAPORE

UPPLITE TRADING

Amk Techlink, Blk 20, Ang Mo Kio Industrial Park 2A, Unit 02-28, Singapore 567761
Tel: +65-64840073 Fax: +65-6484 0072
Email: upplite@yahoo.com.sg

CHINA

UP-LITE LIGHTING ACCESSORIES FACTORY

No.1, Yong Long Industrial Area, Nansha Jun'an Town, Shunde, Foshan City, China, Postcode 528329
Tel: +86-757-2559 3227, 2559 0227 Fax: +86-757-2559 2227
Email: zhongliang227@163.com Website: www.yli-china.com

SALES AND SERVICE

UP-RIGHT MARKETING SDN. BHD.

(571081-A)

IPOH - PERAK MAIN

PT 14504, Persiaran Batu Gajah Perdana 6, Taman Batu Gajah Perdana, 31550 Pusing, Perak, Malaysia
Tel: +60-5-366 6227 (Hunting Line), 366 4227, 365 4227 Fax: +60-5-366 1227
Email: uprmarketing@gmail.com Website: www.up-right.com.my

P.J. - SELANGOR BRANCH

No.26, Jalan Petaling Utama 8, Taman Petaling Utama, Batu 7, Jalan Klang Lama, 46000 Petaling Jaya, Selangor, Malaysia
Tel: +60-3-7782 9227 Fax: +60-3-7781 0227

J.B. - JOHOR BRANCH

No.17, Jalan Bakawali 52, Taman Johor Jaya, 81100 Johor Bahru, Johor, Malaysia
Tel: +60-7-353 9227 Fax: +60-7-355 6227

BUTTERWORTH - PENANG BRANCH

No.7071, Jalan Ong Yi How, Kawasan Industri Ringan Teras Jaya, 13400 Butterworth, Penang, Malaysia
Tel: +60-4-332 8227, 332 6227 Fax: +60-4-329 9227

KOTA KINABARU - SABAH BRANCH

Lot 82, Lok Kawi Light Industrial Estate, Phase II, km 19, Jalan Penampang, Papar Lama, Lok Kawi, Kuarut, District of Papar 89608, Sabah, Malaysia
Tel: +60-88-75 0227 Fax: +60-88-75 4227

MIRI - SARAWAK BRANCH

Lot 3523, Permy Technology Park, Bandar Baru Permyjaya, 98000 Miri, Sarawak, Malaysia
Tel: +60-85-40 8227 Fax: +60-85-63 5227