

VECK 36 LED



Usage Application :

- Standby Power for LED Lighting
- 3 Hours Duration in Event of Power Failure

Compatible With VITALITE VLD Driver :

- VLD 10/250/40
- VLD 15/350/43
- VLD 25/500/50
- VLD 35/700/50

Specifications :

Polycarbonate Casing

Test Standard :

IEC 61347-2-7
IEC 61347-2-13

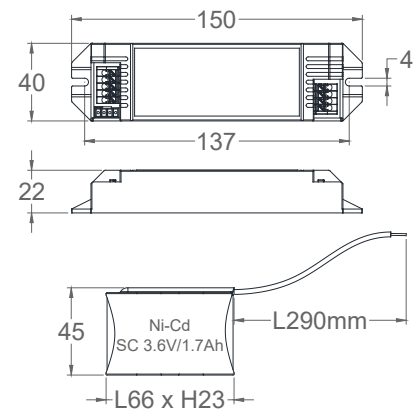
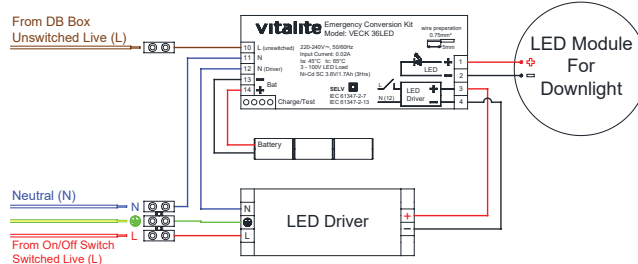

Mains Supply	220 - 240V~ 50/60Hz	Power Consumption	< 2.5W
Mode of Operation	Maintained / Non-Maintained	Input Current / Output Current	0.02A / Max. 60mA
Lamp Type	3 - 100V LED Load	Degree of Protection	IP 20
Battery	Ni-Cd SC 3.6V / 1.7Ah	Max. Temperature t_a / t_c	45°C / 65°C
Emergency Duration	3 Hours	Classification	Class II
Recharge Period	24 Hours	Weight	0.232 KG