



VEL 280/TLS



Specifications :

Polycarbonate Housing
Acrylic Prismatic Diffuser
Adjustable Lamp Head

Test Standard :

MS 619-2-22:2005
MS IEC 60598-1:2012

Mounting Method :

Wall Mounted

Certified by :

SIRIM QAS INTERNATIONAL SDN. BHD.
JABATAN BOMBA DAN PENYELAMAT MALAYSIA

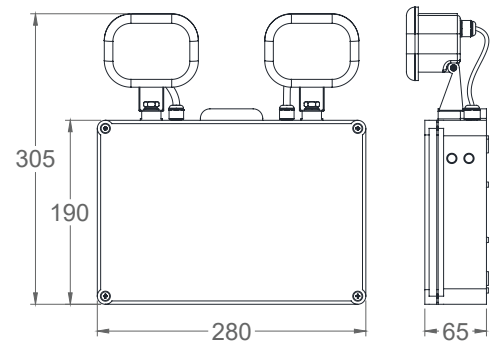

Mains Supply	220 – 240V 50/60Hz	Rating	0.017A / 3.2W / 0.8 PF
Mode of Operation	Non-Maintained	Initial Lumens till 3 Hours	500 lm
Lamp	LED 2835 (2 x 15 PCS)	Classification / Degree of Protection	Class I / IP 65
Battery	Ni-Cd 9.6V C 2500mAh	Max. Operating Temperature (ta)	50°C
Emergency Duration	Min. 3 Hours	Recommended Mounting Height	Min. 3.0m
Recharge Period	24 Hours	Weight	1.78 KG

Packing : 5 Sets Per Carton Box
Outer Carton Box : L495 X W300 X H325 mm (10.40 KG)
Inner Carton Box : L290 X W92 X H305 mm (2.08 KG)