

VEL 260/N/S



Specifications :

Polycarbonate Housing
Mild Steel Gear Tray
Polycarbonate Clear Linear Diffuser

Mounting Method :

Surface Ceiling Mounted
Surface Wall Mounted

Test Standard :

MS 619-2-22:2005
MS IEC 60598-1:2012

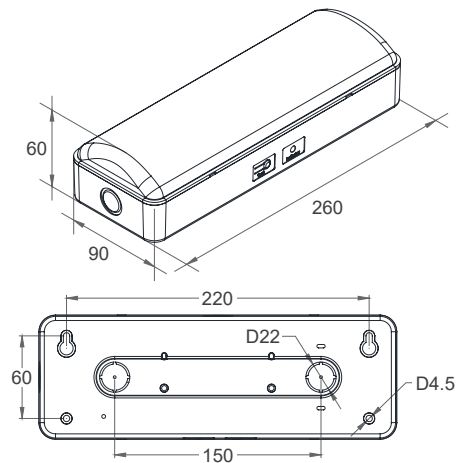

Mains Supply	220 – 240V 50/60Hz	Rating	0.01A / 1.5W / 0.74 PF
Mode of Operation	Non-Maintained	Rated Lumen	140 lm
Lamp	LED 2835 (16 PCS)	Classification / Degree of Protection	Class I / IP 20
Battery	Ni-Cd AA 3.6V 900mAh	Max. Operating Temperature (ta)	40°C
Emergency Duration	3 Hours	Recommended Mounting Height	Min. 3m
Recharge Period	15 Hours	Weight	0.41 KG

Packing : 15 Sets Per Carton Box
Outer Carton Box : L410 x W340 x H295 mm (8.90 KG)
Inner Carton Box : L270 x W105 x H75 mm (0.52 KG)