

### VEL 250/S / VEL 250/R



**VEL 250/S**

Surface Ceiling / Wall



**VEL 250/R**

Recessed Plaster Ceiling



#### Specifications :

Mild Steel Housing  
Mild Steel Ressed Frame  
Polycarbonate Opal Linear Diffuser  
Polycarbonate End Cap

#### Mounting Method :

Surface Ceiling / Wall /  
Recessed Plaster Ceiling  
(Cut Out Size L265mm x W85mm)

#### Certified by :

SIRIM QAS INTERNATIONAL SDN. BHD.  
JABATAN BOMBA DAN PENYELAMAT MALAYSIA

#### Test Standard :

MS 619-2-22:2005  
MS IEC 60598-1:2012

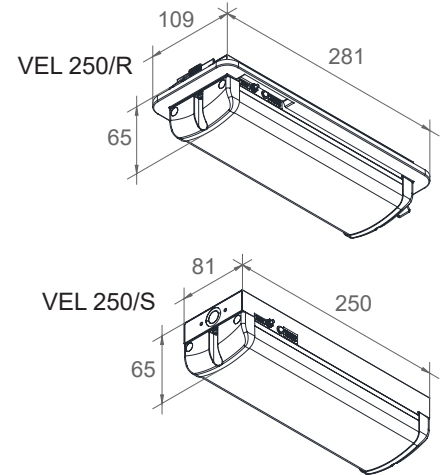

Mains Supply	220 – 240V 50/60Hz	Rating	0.005A / 1W / 0.91 PF
Mode of Operation	Non-Maintained	Rated Lumen Output	62 lm
Lamp	LED 2835 (8 PCS)	Classification / Degree of Protection	Class I / IP 20
Battery	Ni-Cd AA 2.4V 900mAh	Max. Operating Temperature (ta)	35°C
Emergency Duration	3 Hours	Recommended Mounting Height	Min. 3m
Recharge Period	15 Hours	Weight	VEL 250/S
			VEL 250/R

Packing : 15 Sets Per Carton Box  
Outer Carton Box : L380 X W370 X H335 mm (9.72 KG)  
Inner Carton Box : L318 X W117 X H68 mm (0.60 KG)